

ABSOLUTE STEEL HYBRID MODEL 211

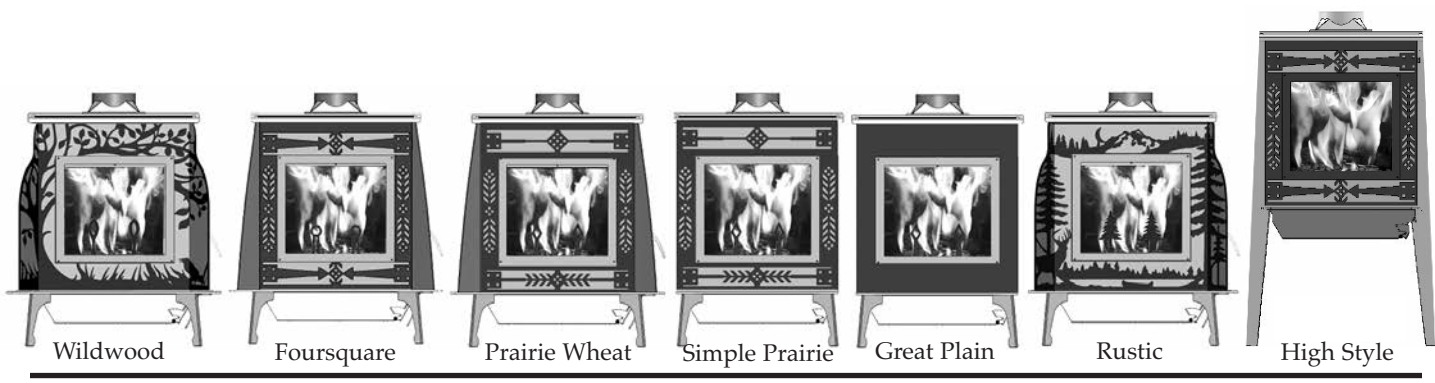

GEAR HEAD STOVES
BY WOODSTOCK SOAPSTONE COMPANY

OWNER'S MANUAL



Tested To UL 1482-2011 7th Edition
Listed By PFS Corporation

Tested and Listed by



Woodstock Soapstone Company, Inc.
66 Airpark Road, West Lebanon, NH 03784
Toll Free 1-800-866-4344 • www.woodstove.com

Rev 0618

OUR PROMISE

We are sure you will enjoy your new stove. During the first six months that you own it, test its performance and experience the comfortable warmth of soapstone. If you are not thoroughly delighted with the beauty, quality, and energy efficiency of your stove, you may return it for a full refund, including the cost of return freight. This is the best consumer protection plan in the industry.

EPA APPROVAL

This Manual describes the installation and operation of: the **Model 211 Absolute Steel Hybrid Catalytic Wood Stove**

The Model 211 Absolute Steel Hybrid Catalytic Wood Stove meets the 2020 Standard U.S. Environmental Protection Agency's crib wood emission limits for wood heaters sold after May 15, 2020. Under specific test conditions, this stove has been shown to deliver heat at rates ranging from 10,000 to 48,000 BTU/hr., and average emissions of 0.5 grams/hr.

The Absolute Steel Hybrid has a manufacturer-set minimum low burn rate that must not be altered. It is against federal regulations to alter this setting or otherwise operate this wood heater in a manner inconsistent with operating instructions in this manual.

The Absolute Steel Hybrid contains a catalytic combustor, which needs periodic inspection and replacement for proper operation. It is against federal regulations to operate this wood heater in a manner inconsistent with the operating instructions in this manual, or if the catalytic element is deactivated or removed.



Tested and Listed by



LISTING TO UL #1482-2011

The **Model 211 Absolute Steel Hybrid Catalytic Wood Stove** has been tested to UL Standard #1482 7th edition 2011 for safety, and is listed by PFS Corporation. UL Standard #1482 is the standard for testing solid fuel heating appliances which is universally recognized by all national building regulatory agencies (SBCC, BOCA, ICBO) and individual states.

Please Note: Tested and Listed for US installations only

LIMITED WARRANTY

Your Woodstock Soapstone Stove will be carefully inspected before shipment. We will replace any part which is defective in material or workmanship, free of cost, for a period of one year from the date of purchase. If a defect is discovered, please contact Woodstock Soapstone Company, Inc. for instructions regarding return or replacement of the defective part.

CATALYTIC COMBUSTOR WARRANTY

The catalytic combustor supplied with your Absolute Steel Hybrid Catalytic Wood Stove is a Clariant Corporation, stainless, durafoil catalyst. The catalyst is fully warranted for three years from the date of purchase against any defect in workmanship or materials that prevent the combustor from functioning when installed and operated properly. The catalytic combustor is additionally warranted for three years from the date of purchase for any deterioration in the stainless steel substrate material. Operating the Absolute Steel Hybrid in a manner inconsistent with the owner's manual will void the catalytic combustor warranty.

For instructions regarding return or replacement of the catalytic combustor, please contact:

Woodstock Soapstone Company, Inc.
66 Airpark Road
West Lebanon, NH 03768
Phone: 1-800-866-4344 • Web: www.woodstove.com

GEAR HEAD STOVES

Gear Head Stoves is a division of Woodstock Soapstone Co., which is specifically 'geared' to designing and building high efficiency, low emission, and more affordable wood stoves. The first Gear Head Stove, The Ideal Steel Hybrid, was the grand prize winner of the 2013 Wood Stove Design Challenge competition, which judged on efficiency, emissions, affordability, innovation, and user friendliness. The Absolute Steel Hybrid is our R2Z (Race to Zero) stove, our internal challenge to design and build a stove that reaches zero wood stove emissions.

MODEL 211

ABSOLUTE STEEL HYBRID CATALYTIC

TABLE OF CONTENTS

WARRANTY INFORMATION / CERTIFICATIONS.....	Inside Cover
EPA Certification, UL Listing, Warranty, Catalytic Combustor Warranty	
INTRODUCTION & EFFICIENCY / EMISSIONS.....	ii-iii
Absolute Steel Hybrid Wood Stove Explained	
INSTALLATION.....	1-12
Installation, Location, Chimneys, Fireplace Installation, Clearance Table, Wall Protection, Floor Protection, Mobile Home Installation, Setting up Your Stove	
OPERATION.....	13-17
Seasoning Your Stove, Starting a Fire and Establishing Draft, Engaging the Catalytic Combustor, Reloading & Overnight Burning, Ash Removal, Surface Thermometer, Overfiring, Daily Use, The Fall-Away Handle, Firewood	
CATALYTIC COMBUSTOR.....	18-21
How your Combustor Works, Inspection & Cleaning, Replacement, Catalytic Probe Thermometer, Frequently Asked Questions, Catalytic Combustor Warranty Information	
MAINTENANCE.....	22-23
Stove, Stone & Glass Cleaning, Gasket Replacement, Routine Checks, End-Of-Season Maintenance, Creosote	
TROUBLESHOOTING.....	24-25
SAFETY.....	26-27
Overview, Installation, Smoke & The Chimney, Heat, Ash Removal, Precautions, Emergency Procedures	
PARTS LIST & DIAGRAMS.....	28-32
MAINTENANCE LOG & NOTE SHEET.....	33
DIMENSION & SPECIFICATIONS.....	Back Cover

Woodstock Soapstone Company, Inc.
66 Airpark Road, West Lebanon, NH 03784
Toll Free 1-800-866-4344 • www.woodstove.com

INTRODUCTION

The Absolute Steel Hybrid Combustion System Explained

The Woodstock Soapstone Company's tradition of building high quality, dependable wood stoves continues in the Absolute Steel Hybrid Wood Stove. This new design combines modern technology to achieve clean and efficient heating performance with rugged reliability and affordable steel construction.

While the Absolute Steel Hybrid shares some time tested features with other members of the Woodstock Soapstone family, it also includes some features that are unique. The Absolute Steel Hybrid has a large glass front that benefits from our proven air-wash design. The firebox is lined with thick soapstone panels, and the exterior is plate steel in order to make the Absolute Steel Hybrid more affordable.

The Absolute Steel Hybrid has a hybrid combustion system similar to the one that we designed in our Ideal Hybrid wood stove. The combination of the catalytic combustor and the secondary combustion system gives the operator a wide range of heat output while maintaining a clean and efficient burn. In addition to the Hybrid combustion design, the Absolute Steel Hybrid incorporates two automatic catalyst air ports to optimize the catalytic combustor's effectiveness.

Hybrid burn technology improves efficiency, lowers emissions, and allows for a wider range of output to meet the heating needs of the operator. Hybrid stoves from Woodstock combine the best attributes of both catalytic combustors and secondary combustion systems. A brief description of each is below, followed by a more detailed explanation.

Catalytic Combustion:

- Burns woodstove exhaust gases starting at 500° F
- Operates best at low to moderate burn rates
- Typically yields long duration burns that are clean and efficient
- Improves stove efficiency by generating heat from burning wood smoke

Secondary Combustion:

- Burns woodstove exhaust gases starting at approximately 1000° F
- Operates best at moderate to high burn rates
- Creates hot firebox for maximum heat output
- Provides a very active fire that is great for viewing

Catalytic combustors are well suited for very long burn cycles. Catalytic combustors have the ability to reduce or eliminate woodstove pollution at low stack temperatures. This means much cleaner, more efficient burns at low firing rates than is possible without a catalyst. The catalytic reaction eliminates harmful combustion byproducts and converts exhaust to water vapor and carbon dioxide. The catalytic combustor burns exhaust gasses and converts them to heat, which is captured inside the stove. This extra heat increases the overall efficiency and output of a catalytic wood stove. The combustor takes full advantage of

the energy in wood smoke that would otherwise be lost up the chimney as pollution and wasted energy at low burn rates.

Secondary combustion systems are designed to maximize efficiency and reduce emissions as well, but they operate differently. The secondary combustion system introduces secondary air in the firebox to ignite the volatile gases produced by the burning wood. This reaction requires temperatures over 1000 degrees F to start breaking down the organic compounds in the wood smoke. Secondary combustion systems work best when the stove has high firebox temperatures and secondary combustion air introduced into the high temperature area at the top of the firebox. With secondary combustion the exhaust gases burn at very high temperatures before leaving the firebox, providing an unusual display of secondary flames in the top of the firebox.

In addition to primary and secondary air, the Absolute Steel Hybrid incorporates a system to introduce air directly to the catalytic combustor as it heats up. When the catalyst is fully engaged two self adjusting, bimetallic strips open small dampers to allow heated air into the exhaust path just upstream from the combustor. This dedicated "catalyst air" keeps the combustor active and helps control primary and secondary burn rates. As the stove and chimney heat up and draft is increased, more catalyst air is added automatically. This has the effect of stabilizing primary and secondary air and at higher temperatures will actually reduce primary and secondary air. The catalyst air design acts similar to a barometric damper. The catalyst air improves emissions and efficiency at high burn rates, provides overfire protection, and stabilizes the burn rate automatically.

These systems are not mutually exclusive and have been designed to work together. The Absolute Steel Hybrid is designed to utilize each system depending on the conditions present in the firebox. This makes operating the Absolute Steel Hybrid as simple as possible while providing a clean and efficient burn over a wider range of heat output.

The Absolute Steel Hybrid wood stove. The perfect combination of affordability, innovative combustion technology, and rugged construction.

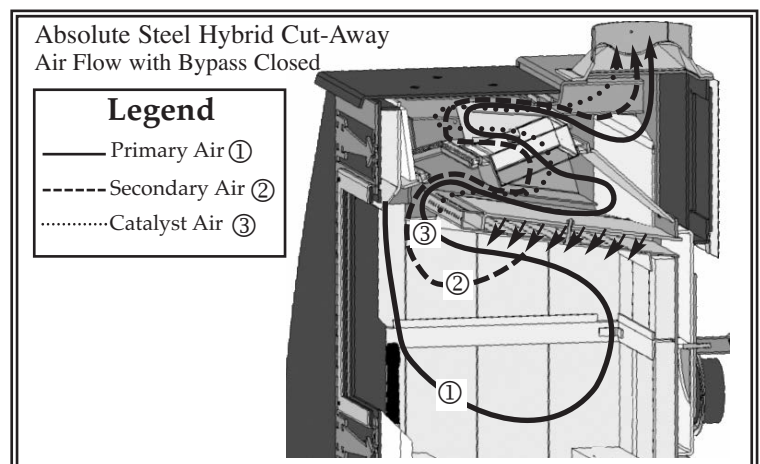

EFFICIENCY & EMISSIONS

Inside Testing of the Absolute Steel Hybrid

EPA TEST DATA

The following data is direct from our 2016 EPA tests for the Absolute Steel Hybrid. The Absolute Steel Hybrid meets/exceeds the 2020 EPA Standard of 2.0g/hr maximum emissions set by the EPA in 2015. The current test protocol specifies "crib wood" using dimensional Douglas Fir. The efficiency is determined using High Heat Value (HHV). The weighted emissions average is 0.50 grams per hour, and the weighted efficiency is 77%.

Model 211 Absolute Steel Hybrid

Test No.	Burn Rate kg/hr	Test Mi _n	Ave. Emission Rate g/hr	HHV (OHE)	Heat Output (BTU/HR)	Weighting Factor
1	0.956	399	0.140	80.30	14,426	24.18%
2	1.042	354	0.200	79.50	15,213	22.42%
3	1.415	269	0.500	74.80	19,895	19.29%
4	1.451	279	0.420	76.20	20,797	17.38%
5	3.411	105	1.520	70.70	45,317	16.74%
Weighted average emissions rate:					0.50 g/hr	
Weighted Average Heating Efficiency (OHE)					77%	

FACTORS EFFECTING EFFICIENCY & EMISSIONS

1. **Burn Rate:** As shown in the table above the lowest emissions and greatest efficiency was achieved by running the Absolute Steel Hybrid at a low-medium burn rate (indicated in Tests 1-4). A lower burn rate gives the combustor more time to effectively burn the volatile gases as they enter into the catalytic combustor (see discussion in the Catalytic Combustor Section of the Manual). When operating your stove at a lower burn rate you will achieve a cleaner burn over a longer period of time. Low burn rates are also how you achieve desirable long burn times of 10+ hours.

2. **Wood Quality:** Cord wood with a moisture content between 15-22% is ideal for burning. The Absolute Steel Hybrid will still burn wood with a higher moisture content with great effectiveness, however, the energy loss at start up and reloading is significant. During the first stage of wood burning the moisture content within the wood is expelled creating steam. The higher the moisture content the lesser the available heat value.

Kiln Dried Wood: Approximately 8600 BTU Available/per pound

20% Moisture Content: Approximately 6,200 BTU Available/per pound

50% Moisture Content: Approximately 4,000 BTU Available/per pound

3. **Effective Fire Starting:** The most effective method for an emissions free start is a top down fire. A top down fire is built with the larger splits on the bottom of the firebox, the second layer should be medium sized splits, and if possible running perpendicular to the large splits on the bottom, and the third layer should be small splits. On top of the small splits a generous amount of small very dry kindling and newspaper will be placed at the top. The newspaper and kindling will produce enough heat very quickly allow in the secondary air and catalytic combustor to ignite within minutes. You may need to leave the loading door cracked open to allow enough oxygen in for a quick start. Within a few minutes you should be able to engage the combustor and start the clean burn cycle.

DIMENSIONS & SPECIFICATIONS

Dimensions of Standard Height Stoves:

Curved Wing & Triangle Wing Styles:

H x W x D (includes ash lip & skirting)..... 33.25"x30"x27.25"

Wingless Styles:

H x W x D (includes ash lip & skirting)..... 33.25"x25.5"x24"

Footprint..... 25" W x 20" D

Flue Height to Center (Rear Vent)..... 28"

Weight..... 490 lbs.

Dimensions of High Style Stove:

H x W x D (includes ash lip & skirting)..... 45.5"x 27"x 25.125"

Footprint..... 25.5" W x 21.125" D

Flue Height to Center (Rear vent)..... 40.625"

Weight..... 530 lbs.

Specifications for All Absolute Styles:

EPA Certified..... Yes

Listed to UL 1482..... Yes

EPA Emissions Rating..... 0.5 grams/hr

EPA Efficiency..... 77%

Catalytic Combustor & Secondary Air Standard

Bottom Heat Shield..... Standard

Area Heated..... up to 1,800 sq. ft.

Flue Exit..... Top or Back

Flue Size..... 6"

Ash Pan..... Optional

Loading Door..... Right or Left Side

Loading Door Opening (W x H)..... 12"x10"

Draft Control..... Manual

Back Clearance (no protection)..... 14"

Back Clearance (w/Heat Shield Kit)..... 8.5"

Side Clearance..... 26"

Wood Length (Maximum)..... 16-18"

Window Size (viewable)..... 14.5" W x 13" H

Firebox Size..... 2.45 Cubic ft.

Burn Time..... 10-14 hrs.

Heat Output Range..... 10,000-48,000 BTU/hr.

Absolute Standard Leg Height Styles:

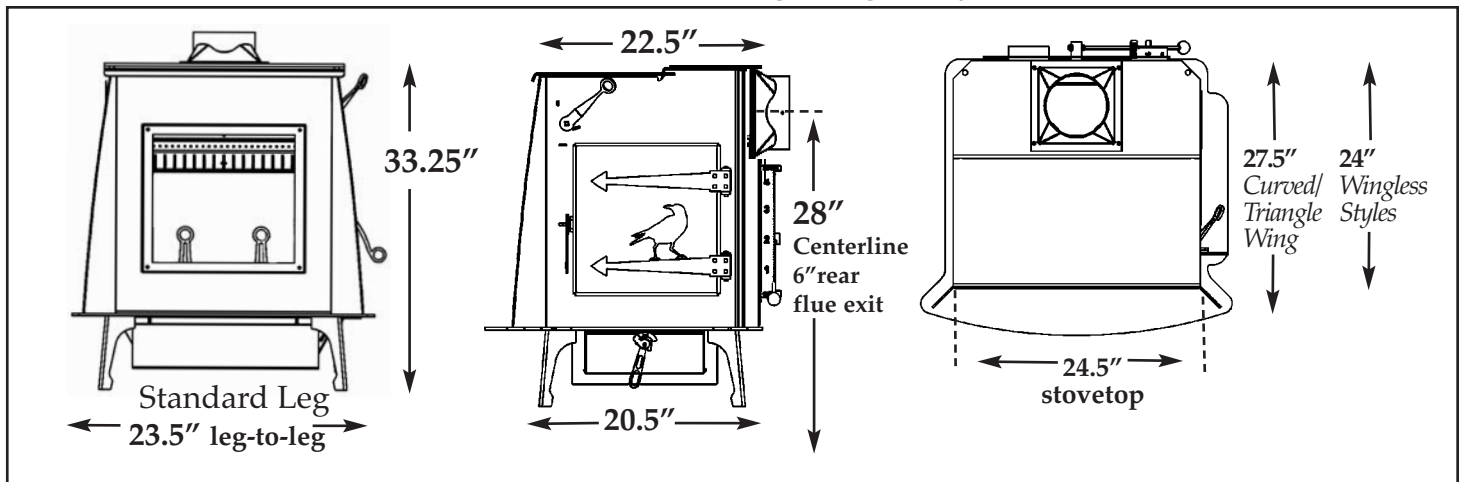

Absolute "High Style" Model:

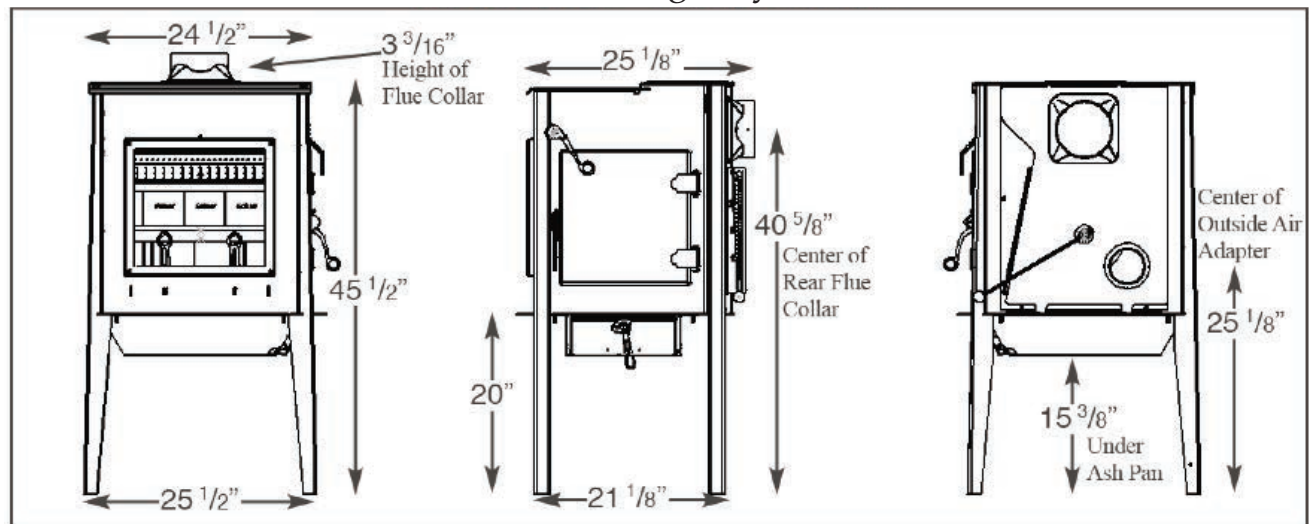



GEAR HEAD STOVES
BY WOODSTOCK SOAPSTONE COMPANY