

# PROGRESS HYBRID

## MODEL 209a

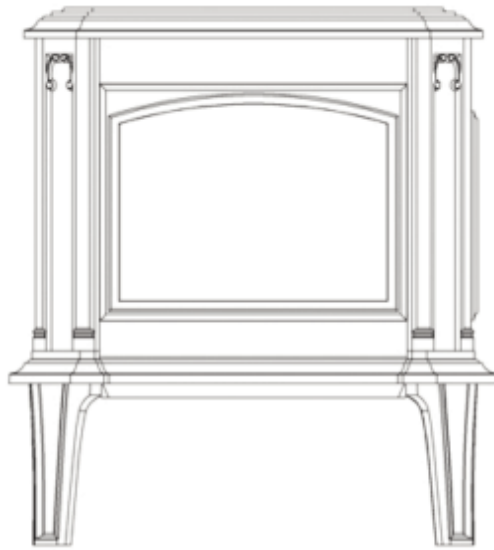

---

# WOODSTOCK SOAPSTONE STOVES

## OWNER'S MANUAL

Tested To UL 1482-2011 7th Edition  
Listed By PFS Corporation

Tested and Listed by



Woodstock Soapstone Company, Inc.  
66 Airpark Road, West Lebanon, NH 03784  
Toll Free 1-800-866-4344 • [www.woodstove.com](http://www.woodstove.com)

Rev 0221

## OUR PROMISE

We are sure you will enjoy your new stove. During the first six months that you own it, test its performance and experience the comfortable warmth of soapstone. If you are not thoroughly delighted with the beauty, quality, and energy efficiency of your stove, you may return it for a full refund, including the cost of return freight. This is the best consumer protection plan in the industry.

## EPA APPROVAL

This Manual describes the installation and operation of: the **Model 209a Progress Hybrid Catalytic Soapstone Stove**

**Model 209a Progress Hybrid Catalytic Soapstone Stove** meets the U.S. Environmental Protection Agency's emission limits for wood heaters sold after May 15, 2020. When tested with cord wood, this stove has been shown to deliver heat at rates ranging from 13,149 to 47,220 BTU/hr., and average emissions of 0.63 grams/hr.

The Progress Hybrid contains a catalytic combustor, which needs periodic inspection and replacement for proper operation. It is against the law to operate this woodstove in a manner inconsistent with the operating instructions in this manual, or if the catalytic element is deactivated or removed.

This wood heater has a manufacturer-set minimum low burn rate that must not be altered. It is against federal regulations to alter this setting or otherwise operate this wood heater in a manner inconsistent with operating instructions in this manual.

## LISTING TO UL #1482

Tested and Listed by



**Model 209a Progress Hybrid Catalytic Soapstone Stove** has been tested to UL Standard #1482 7th edition 2011 for safety, and listed by PFS Corporation. UL Standard #1482 is the standard for testing solid fuel heating appliances which is universally recognized by all national building regulatory agencies (SBCC, BOCA, ICBO) and individual states.

**Please Note:** Tested and Listed for US installations only

## LIMITED WARRANTY

Your Woodstock Soapstone Stove will be carefully inspected before shipment. We will replace any part which is defective in material or workmanship, free of cost, for a period one year from the date of purchase. If a defect is discovered, please contact Woodstock Soapstone Company, Inc. for instructions regarding return or replacement of the defective part.

## CATALYTIC COMBUSTOR WARRANTY

The catalytic combustor in your Progress Hybrid Woodstove is fully warranted for three years from the date of purchase against any defect in workmanship or materials that prevent the combustor from functioning when installed and operated properly. The catalytic combustor is additionally warranted for three years from the date of purchase for any deterioration in the stainless steel substrate material. For instructions regarding return or replacement of the catalytic combustor, please contact:

Woodstock Soapstone Company, Inc.  
66 Airpark Road  
West Lebanon, NH 03768  
Phone: 1-800-866-4344 • Web: [www.woodstove.com](http://www.woodstove.com)

# MODEL 209a

## PROGRESS HYBRID CATALYTIC

### TABLE OF CONTENTS

WARRANTY INFORMATION / CERTIFICATIONS.....	Inside Cover
EPA Certification, UL Listing, Warranty, Catalytic Combustor Warranty	
INTRODUCTION	
Progress Hybrid Wood Stove Explained	
INSTALLATION.....	1-14
Installation, Location, Chimneys, Fireplace Installation Clearance Table, Wall Protection, Floor Protection	
OPERATION.....	15-20
Setting up Your Stove, Seasoning Your Stove, Starting a Fire and Establishing Draft, Engaging the Catalytic Combustor, Re-loading & Overnight Burning, Ash Removal, Surface Thermometer, Overfiring, Daily Use, The Fall-Away Handle, Firewood	
CATALYTIC COMBUSTOR.....	21-24
How your Combustor Works, Inspection & Cleaning, Replacement, Catalytic Probe Thermometer, Frequently Asked Questions, Catalytic Combustor Warranty Information	
MAINTENANCE.....	25-27
Stove, Stone & Glass Cleaning, Gasket Replacement, Routine Checks, End-Of-Season Maintenance, Creosote	
TROUBLESHOOTING.....	28-29
SAFETY.....	30-31
Overview, Installation, Smoke & The Chimney, Heat, Ash Removal, Precautions, Emergency Procedures	
PARTS LIST & DIAGRAMS.....	32-35
SPECIFICATIONS.....	Back Cover

# Introduction

In many ways, the Progress Hybrid was inspired by our customers' request for a larger wood stove capable of heating large spaces. Many wanted the choice of top or rear venting and right or left side loading. A large ash pan option also made the list. Of course everyone wanted a grand view of the mesmerizing flames. All of these features made it into the final design, but this was not good enough for us. We wanted this new wood stove to exceed the efficiency of any stove in production and deliver its soul soothing warmth with one of the most efficient burns, and lowest emissions in the industry. How could we achieve these goals? Hybrid technology.

Why is the Progress called a Hybrid? It is a hybrid because it combines two distinct and proven combustion technologies to achieve our goals of high efficiency and low emissions. Government regulations and increased public concern regarding air quality over the past few decades have led the wood stove industry to develop cleaner burning stoves. These stoves have used either catalytic combustors or a secondary combustion system- until now. The Progress Hybrid is the first wood stove in the industry to combine these two systems and reap the benefits of both to produce one of the cleanest burning and most efficient stoves available today. Each system on its own has distinct advantages. A brief description is below followed by a more detailed explanation.

Catalytic Combustors:

- Burn wood smoke starting at 500° F
- Operate best at low to moderate burn rates
- Yield clean, efficient, long duration burns
- Add to wood stove efficiency by generating heat from burning wood smoke

Secondary Combustion Systems:

- Burn wood smoke starting around 1000° F
- Operate best at moderate to high burn rates
- Deliver maximum heat output
- Provide a very active fire that is great for viewing

Catalytic combustors are well suited for longer duration, moderate burning. They have the ability to break down the organic compounds in wood smoke at lower temperatures. This leads to a cleaner burn than older stoves that allowed the wood to smolder when choked down for longer burn times. The catalytic reaction reduces harmful combustion by-products to mainly water vapor and carbon dioxide. As the compounds are broken down through this reaction a substantial amount of heat is released as well. This extra heat increases the overall efficiency of a catalytic wood stove. The combustor has the ability to take advantage of the fuel value of the wood smoke before the smoke leaves the stove as pollution and wasted energy.

Secondary combustion systems are designed to maximize efficiency and reduce emissions as well, but they operate differently. The secondary combustion system incorporates a secondary air source to ignite the volatile gases produced by the wood burning in the firebox. This reaction requires temperatures over 1000 degrees F to effectively start breaking down the organic compounds in the wood smoke. Secondary combustion systems will work best in a stove that is designed to maintain high firebox temperatures and allow the right amount of secondary combustion air into that high temperature area. The gases burn at very high temperatures as the smoke is broken down into simpler compounds in the firebox.

The Progress Hybrid incorporates a large catalytic combustor as well as a secondary combustion system. It has been designed to deliver the maximum amount of heat from the wood and smoke it burns while minimizing the pollution released to the atmosphere. One simple lever controls the flow of primary as well as secondary air into the firebox. The amount of air, temperature of the firebox, and the

amount of fuel (smoke and gasses) present will dictate which system (or both) is most active. Simply allowing more air into the firebox will generate more heat there, while also increasing the amount of oxygen to light off the secondary combustion process. The result is a spectacular light show as the secondary flames swirl and tumble around the firebox. The entire stove body will radiate warmth for hours. Less air to the firebox will slow the primary combustion, and create the ideal conditions for an effective catalytic reaction. The catalytic combustor will become very active as the smoke and oxygen not consumed in the firebox will provide it with the necessary ingredients to effectively break down the compounds in the smoke, and generate substantial heat at the top of the stove. Heat will be delivered to your home very evenly and moderately for twelve hours or more.

These two systems are not mutually exclusive and have been designed to work together. The Progress Hybrid is designed to utilize each system or both depending on the conditions present in the firebox. This makes operating the Progress as simple as possible while providing a clean and efficient burn over a wider range of heat output.

This hybrid design makes the Progress the perfect marriage of modern combustion technology and the timeless beauty and function of soapstone.

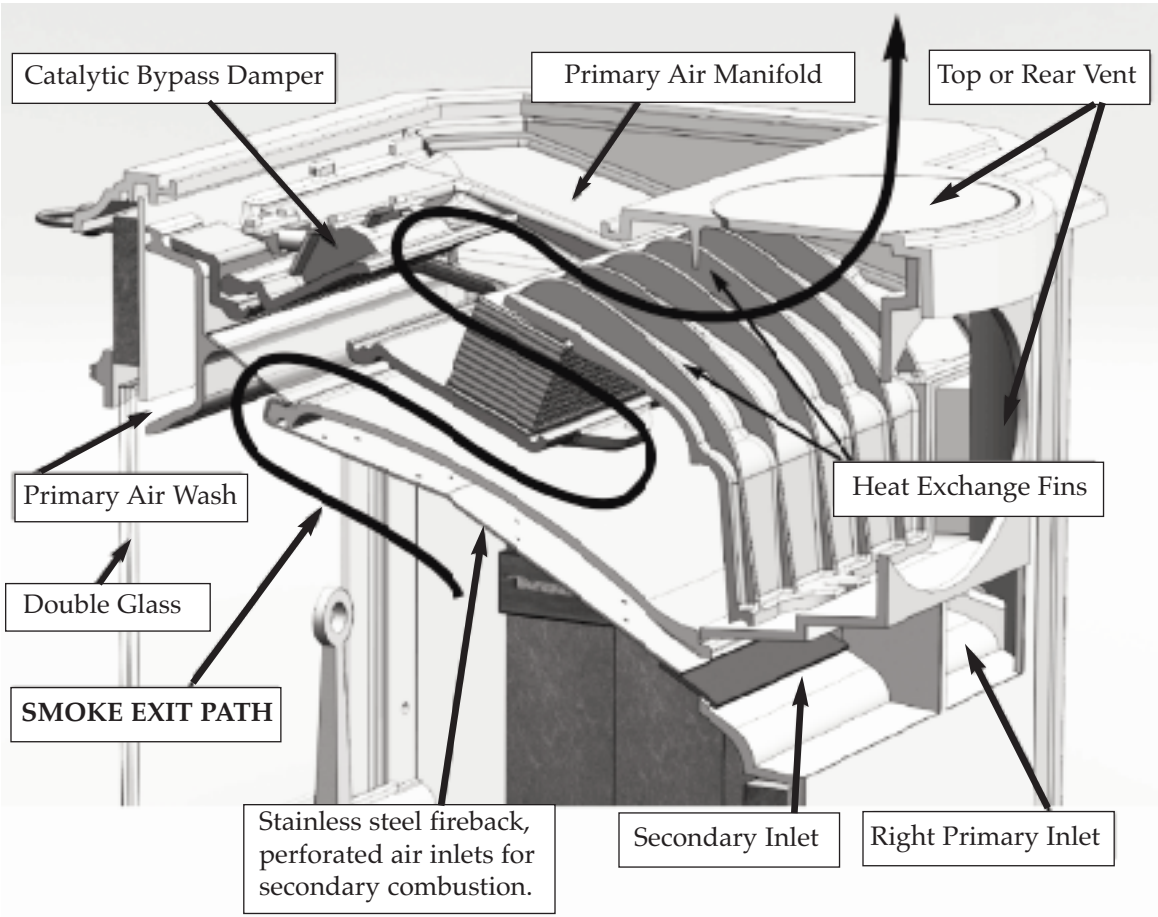

# INSTALLATION

For over two centuries, New Englanders have heated their homes with soapstone stoves. A properly installed and operated soapstone stove will warm your home and delight your eye for a lifetime.

**Read this entire manual carefully.** It explains how to install your Woodstock Soapstone Progress Hybrid Wood Stove safely and how to operate it correctly and efficiently. The clearances and procedures recommended in this guide are in compliance with the recommendations of the National Fire Protection Association (NFPA), the Underwriters Laboratories (UL), and the U. S. Environmental Protection Agency (EPA). You may feel some of them are very stringent, but they should be followed. They were designed to protect you, your home, and the environment. **Improper installations are a major cause of serious fires. Failure to follow instructions may result in property damage, bodily injury, or death.**

Before installing a woodstove, check your local building codes and any requirements established by your insurance company.

You may need a local building permit to install your stove. Any changes in your home must comply with building codes. If the codes have not been fully updated, you may want to check with the Building Inspection Department or your local Fire Department. A qualified stove installer should be aware of any changes and updates to local and state codes and may be best suited to handle your installation work.

Many chimney sweeps are qualified installers. If you are unfamiliar with sweeps or need to locate a certified sweep in your area, you can check listings at [www.csia.org](http://www.csia.org) (Chimney Safety Institute of America). Builders and contractors are another option. In some cases, homeowners install their own stoves. Before installing your stove, please review carefully the stove installation, clearance, and safety information in this manual. Woodstock Soapstone has NFI (National Fireplace Institute) certified woodburning specialists on staff and available to answer any questions you may have about your installation. If you have questions, please call us toll free at 1-800-866-4344.

You should notify your insurance company that you are using a woodstove. Before you light your first fire, have a local building inspector and your insurance representative inspect, and approve in writing, your installation.

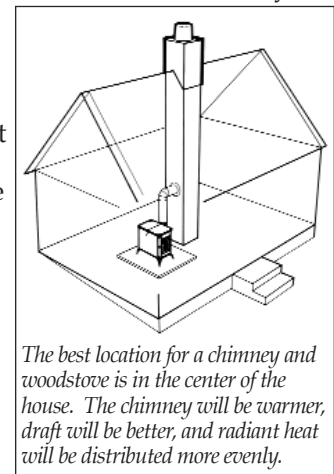

*The best location for a chimney and woodstove is in the center of the house. The chimney will be warmer, draft will be better, and radiant heat will be distributed more evenly.*

**THE PROGRESS HYBRID IS NOT APPROVED FOR INSTALLATION IN MOBILE HOMES.**

## LOCATION

A stove which is centrally located will heat the greatest area of your home. Heat should be able to circulate easily into nearby rooms. Placing your stove near an open stairway or register in the floor will help transfer heat to other rooms.

Other installation considerations are:

- Clearance to Combustibles
- Adequate Space for Wood Loading and Ash Removal
- Room Traffic Patterns

Most people install their stove in a room they use frequently where they can enjoy the beauty and comfort of the stove. This also helps in ease of the monitoring and reloading the stove as needed.

A well-planned placement will enhance your enjoyment of your stove and may save installation costs.

### **ALCOVE INSTALLATIONS**

The Model 209 Progress Hybrid Woodstove is **not** approved for an alcove installation. An alcove is described as an area less than 512 cubic feet, which is equivalent to an 8'x8'x8' space.

# CHIMNEYS

Your chimney is a critical component of your wood heating system. A properly designed and constructed chimney will help to provide safe and efficient woodstove operation. Hot exhaust rising up through the chimney also pulls combustion air into the stove through the air damper. If a chimney is too short, or the flue too large, the hot exhaust will cool and slow down. This can lead to poor stove performance, smoke spillage, back puffing, and even creosote build up in the chimney itself. An excessively tall chimney could lead to a strong draft, which may make the fire difficult to control with the stove damper. This could result in over firing the stove and lead to damage to the cast iron components as well as the catalytic combustor. Whether you are installing a new chimney, or adapting an existing chimney to your woodstove, close attention to chimney height, flue size, and location should be considered.

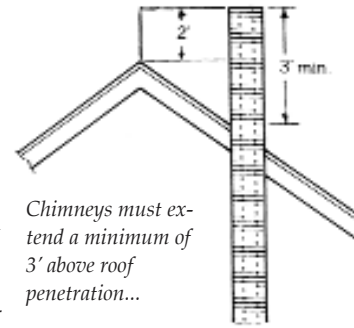

Chimneys must extend a minimum of 3' above roof penetration...

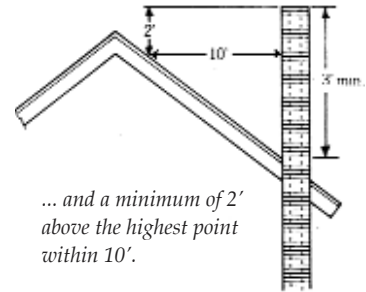

... and a minimum of 2' above the highest point within 10'.

## Chimney Flue Sizing:

The ideal flue size for the Progress Hybrid is 6" - the same diameter as the stove's flue collar. If upsizing needs to occur due to an existing chimney the following general rules apply:

1. **Interior Chimney** (no walls of the chimney exposed to the outside below the roofline): the inside cross-sectional area of your chimney should be no more than 3x the cross-sectional area of the woodstove flue collar.
2. **Exterior Chimney** (if there are one or more walls exposed to the outside below the roofline) - The flue should be no more than 2x the cross-sectional area of the flue collar.

**Recommendation:** The Progress Hybrid has a 6 inch flue collar, thus an 8 inch x 10 inch rectangular or 10 inch round flue tile for an **inside** chimney are the maximum flue sizes we recommend for this stove. For an **outside** chimney, an 8 inch x 8 inch square or 8 inch round would be the largest acceptable. The smallest size we recommend is 6 inches round, as the flue should not be less than the flue collar size.

Note: For flues that exceed the recommended area, a stainless steel chimney liner is recommended.

### Height Requirements:

The chimney must extend 3 ft. above the point where it passes through the roof and must also be 2 ft. higher than any roof surface or obstruction within 10 feet (measured horizontally) of the chimney. You should check your local building codes for any other requirements.

The recommended minimum chimney height is 15 feet from the flue collar of the stove to the top of the chimney. This includes connector pipe and chimney pipe. There may be other factors to conform to code for clearances on the roof, high wind, high altitude, etc., that may make the *minimum* height undesirable or a violation of building codes.

## CHIMNEY TYPES

**DO NOT CONNECT THIS UNIT TO A CHIMNEY FLUE SERVING ANOTHER APPLIANCE.**

There are two acceptable types of chimneys: Lined Masonry Chimneys and Class A, Pre-fabricated Metal Chimneys rated to 2100° F. Masonry chimneys must meet all applicable codes for a safe installation.

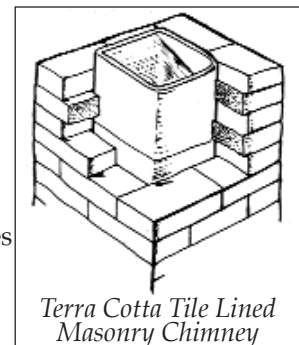

Terra Cotta Tile Lined Masonry Chimney



Installing a Stainless Steel Liner in a Masonry Chimney

## Lined Masonry Chimneys:

Always have the chimney inspected prior to your stove installation. If your chimney is not lined with appropriately sized clay flue tiles, or the clay tiles are old, cracked, damaged or otherwise compromised, a stainless steel chimney liner or poured liner will be required. Depending on the condition of your flue or clay tiles, the stainless steel liner may need to be wrapped in a high temperature insulation blanket. A liner may also be recommended if your flue is too large for the draft to flow properly (please refer to the section on chimney sizing). Our customer service department can answer any questions regarding the use of a liner and/or insulating blanket. Call 1-800-866-4344.

Existing chimneys should be checked twice a year for obstructions, creosote deposits, surface cracks, chemical deterioration and poor construction. Any damage should be repaired immediately. Two other chimney related areas that should be checked are chimney penetrations at the floor or ceiling joists, and at the roofline. There should be at least 2 inches of clearance between the chimney and floor joists or other combustible materials. Poor flashing between the chimney and the roof line can cause leaks and deterioration of chimney mortar.

You should make preliminary checks, but if you have any doubts, or are unfamiliar with chimney construction, cleaning, or maintenance, have a local fire official or certified chimney professional inspect your chimney. If repairs are required, be sure to use someone who is knowledgeable in chimney work and familiar with local code requirements.

In addition: All brick or cinder block chimneys should have clean out access with a tight fitting door. Masonry chimneys should have a wash at the top. All chimneys should have a cap to keep out rain and snow and to minimize downdrafts caused by wind.

## Passing Through A Combustible Wall:

With an exterior chimney, in most cases the chimney connector (or stove pipe) will need to pass through a combustible wall. The following are acceptable methods:

**A. Use a section of Solid Insulated Prefabricated Metal Chimney to connect to the chimney** - Use a section of insulated prefabricated 2100° Class A chimney pipe listed to UL 103 HT (at least 1" of insulation or greater) the same inside diameter as the stove pipe and maintain a 9" air space between the wall of the prefabricated chimney and the combustible wall. This section of chimney pipe can be supported by a sheet metal plate securely fastened to the combustible wall, with a hole cut in the middle of it. This will close the gap around the chimney pipe and the framed opening. (See Diagram A Below)

**B. Build a solid brick surround around a tile liner** - Frame a 3.5" thick brick surround into the combustible wall you need to pass through. Maintain a minimum 12" brick separation from the clay liner to combustibles. The minimum 5/8" thick clay liner should be cemented in place and run from the outer surface of the brick to the inner surface of the chimney. (See Diagram B Below)

**C. There are also UL Listed kits available** that are specifically designed for passing through a combustible wall. For more information on these kits, please contact Woodstock Soapstone Company. Please note: there are several UL listed wall pass through kits available, always follow the manufacturers specific installation instructions. (See Diagram C Below)

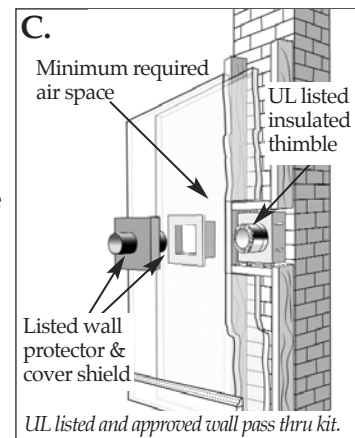
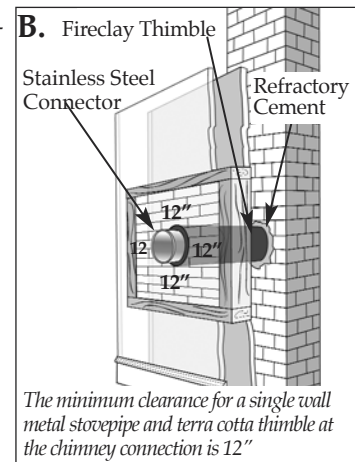
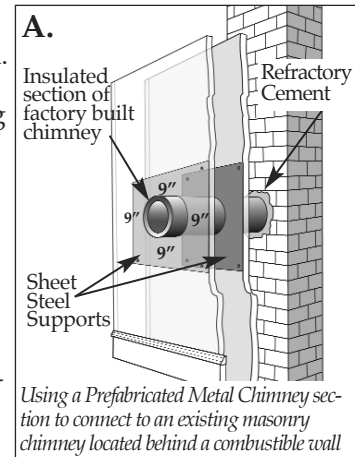
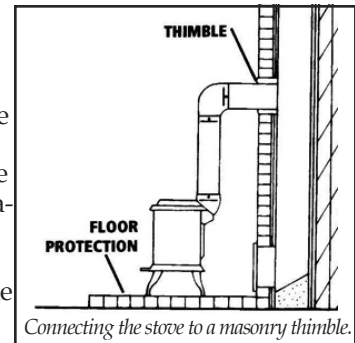



For other methods, please refer to NFPA 211.

REMEMBER, UNPROTECTED SINGLE OR DOUBLE WALL STOVE PIPE SHOULD NOT PASS THROUGH A COMBUSTIBLE WALL OR CEILING TO CONNECT TO THE CHIMNEY. YOU MUST USE AN APPROVED METHOD WHICH PROVIDES GREATER PROTECTION THAN SINGLE OR DOUBLE WALL PIPE.

## Prefabricated Metal Chimneys:

For high efficiency, freestanding woodstoves, like your Woodstock Soapstone stove, a Prefabricated Metal Chimney must be listed as Class A and carry a UL Listing of 103 HT (high temperature). The "UL 103 Type HT Class A" prefabricated chimney will have a temperature rating of 2,100° F.

There are prefabricated chimney systems that are approved to 1,700° F and are generally used with fireplace inserts or factory built fireplaces. These **ARE NOT** suitable for use with your Woodstock Soapstone stove.

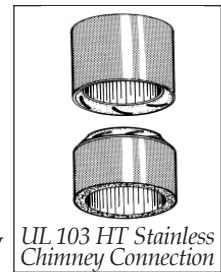

At the point of the first penetration of a combustible surface (i.e., wall or ceiling) all subsequent venting components need to be prefabricated "UL Type HT Class A". If your prefabricated chimney goes through a living space it must be enclosed, and that enclosure must conform to clearance standards for the prefabricated chimney. Your chimney must pass through your roof and extend above the roof line in accordance with code standards. Please refer to height requirements on Page 2.

## PREFABRICATED CHIMNEY CONFIGURATIONS

The diagrams below represent the most common and acceptable installations using prefabricated chimney pipe. The necessary components are listed and shown in their appropriate locations. These components are Class A listed to U.L. 103HT (tested to 2100 degrees F.) Only components listed to U.L. 103HT can be used to install your wood stove. Installation instructions are described below for examples only. More detailed instructions are available through Woodstock Soapstone or the pipe manufacturer. **ALWAYS FOLLOW THE MANUFACTURER'S SPECIFIC INSTALLATION INSTRUCTIONS.**

### Installation 1- Flat ceiling through the roof

First, determine where the stove will be placed. Pay close attention to all required clearances for the stove **and** connector pipe. Next, use a plumb line to locate the Finish Ceiling Support in the ceiling above. Cut the appropriate sized hole in the ceiling and frame in the necessary supports to secure the ceiling support. Install the pipe adapter onto the first section of chimney pipe, and lower them into the Ceiling support. Use an insulation shield in the attic to keep any insulation away from the pipe. If the attic is a living space the chimney pipe must be fully enclosed. As the pipe extends through the roof, install the appropriate flashing and storm collar to keep the weather out. As the height of the chimney increases to meet code, it may be necessary to install a roof brace (typically recommended at 5' intervals). All chimneys should have the appropriate cap installed at the top to reduce wind and weather related downdrafts as well as deter any animals from building nests. The connector pipe should extend from the flue collar of the stove to the pipe adapter at the ceiling support. The male (crimped) end should always point down toward the stove. Be sure that each joint has enough overlap for a secure connection. All connections should be fastened with screws, including at the flue collar and pipe adapter. (Please refer to the manufacturers full set of installation instructions)

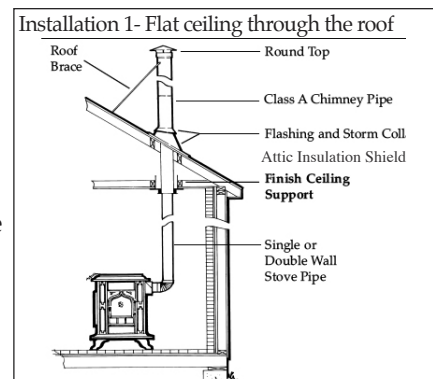

### Installation 2- Pitched/Cathedral Ceiling through the roof

Determine where the stove will be placed. Be sure all clearance requirements are satisfied. Choose the appropriate support for your installation (Support box or Roof support package). Use a plumb line to locate the support in the ceiling above. Cut the appropriate sized hole in the ceiling and install the necessary framing to secure the support. Install the support according to its specific instructions.. Be sure that

the support hangs down below the ceiling far enough to maintain proper clearance to the connector pipe (steeper slopes require more pipe below the ceiling). Install the pipe adapter to the first section of chimney pipe and lower it into the support box (or connect it to the bottom of the roof support). As the pipe extends through the roof install the appropriate roof flashing and storm collar. Install the proper chimney pipe lengths to meet code and recommended chimney height. It may be necessary to install a roof brace for stability. Always install the appropriate cap to the top of the chimney. Double wall connector pipe is recommended for installations that have 10' or more from the stove to the chimney. Be sure that all joints in the connector pipe are secure and fastened with screws, including at the flue collar and chimney pipe adapter. (Please refer to the manufacturer's full set of installation instructions).

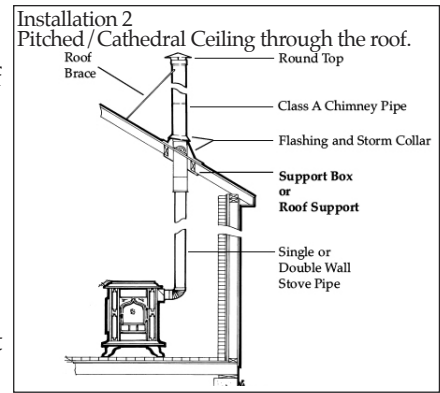

### Installation 3- Through the wall

This installation requires the use of an insulated wall thimble to penetrate a combustible wall. Typically a 9"-12" chimney pipe and pipe adapter will pass through the thimble and make the connection between the interior connector pipe and an insulated tee with a clean out on the outside of the building. The tee and chimney rising up from it rest on a wall support designed to bear the weight of the chimney. Install lateral supports as specified as the chimney rises along the exterior wall. The appropriate flashing and storm collar should be installed if the chimney penetrates an eave or overhang. An offset of 15 or 30 degrees may also be used to go around an overhang. As the chimney extends above the roof to meet code it may be necessary to install a roof brace. (Please refer to the manufacturer's full set of installation instructions).

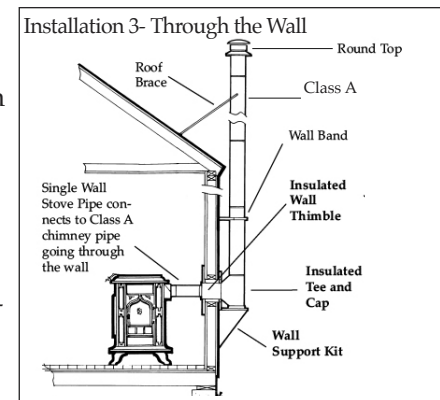

### Stovepipe (Connector Pipe):

Connector pipe is either single wall (sheet metal) or double wall (sheet metal outer pipe with a stainless steel inner pipe). We strongly recommend 22 gauge pipe (26 or 28 gauge is too thin for use with a woodstove). The connector pipe should be 6 inch diameter to match the flue collar of the stove. If your connection to either a masonry chimney or prefabricated chimney system is more than 8 feet tall, we recommend the use of double wall connector pipe. If you need to reduce clearances for your connector pipe installation, double wall connector pipe would be recommended. All pipe connections, including at the flue collar, must be secured with screws. **DO NOT USE GALVANIZED SINGLE WALL PIPE.**

Connector pipe is designed to connect your stove to your masonry lined or approved prefabricated chimney system. **CONNECTOR PIPE SHOULD NEVER BE USED AS A CHIMNEY AND SHOULD NEVER PASS THROUGH A COMBUSTIBLE WALL, CEILING, WINDOW, CLOSET, OR ROOF.** At the point where your stovepipe meets the chimney, you must either vent into a masonry chimney with approved non-combustible transition, or a prefabricated chimney system with a specially designed transition piece.

## FIREPLACE INSTALLATION

Your Model 209 Progress Hybrid Woodstove has the option of short legs to make it more adaptable to venting through an existing fireplace. The short legs lower the height of the stove by 5 inches. The center-line height of the rear flue exit drops from 27.75" to 22.75". Installing the Progress Hybrid soapstone stove in a fireplace setting is a great way to enjoy the view of the fire, while greatly increasing the efficiency and reducing heat loss to the fireplace chimney. **NOTE: The short legs do not allow for the installation of an ash pan.**

We do not recommend placing the stove inside the fireplace, as it would be difficult to access the control levers, load the stove, and much of the heat radiating off the stove would not circulate into the room.

The preferred method for installing a stove in front of a fireplace is by running a stainless steel 'flex' liner down the chimney, connecting it to the stove at the fireplace. Chimneys with large flues should be re-lined to achieve proper draft. If the chimney does not have a flue tile or if the tile is cracked or compromised, an additional insulating material must be used.

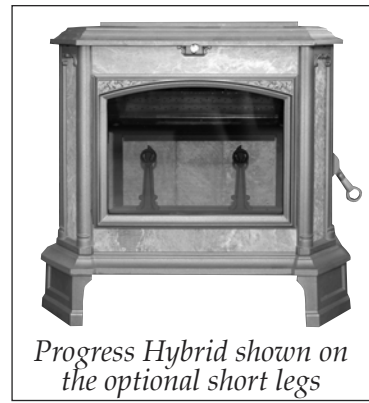

It is important that there be a secure connection between the stove and the flue liner. It is **NOT** acceptable to simply install a plate in front of the fireplace and run a stovepipe through it. The stove pipe must connect with the liner for a continuous outlet to the top of your chimney.

Stainless steel flex liner kits come in a variety of lengths and are readily available. These kits include a flexible stainless steel pipe, tee with snout & clean out, a block-off plate for the top of the chimney and a cap. Please contact Woodstock Soapstone Company for more information on these kits. **ALWAYS FOLLOW THE MANUFACTURER'S SPECIFIC INSTALLATION INSTRUCTIONS.**

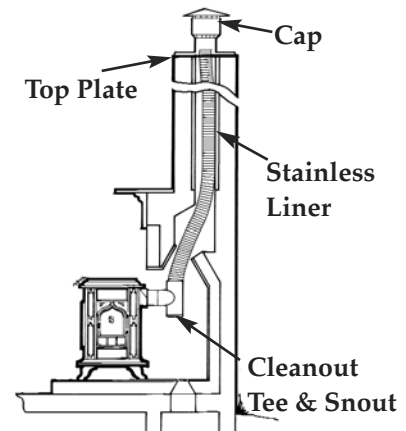

If the fireplace surround is clad in wood trim, the proper clearance to a combustible will need to be maintained. Please refer to the clearance charts. An unprotected wood mantel needs to be a minimum of 30" from the top of the stove. If a mantel shield is installed that clearance can be reduced to 12".

**DO NOT VENT YOUR WOOD STOVE THROUGH A FACTORY BUILT FIREPLACE UNLESS IT IS SPECIFICALLY LISTED FOR SUCH AN INSTALLATION.** Most factory-built fireplace chimney systems are only rated to 1,700° F, which is not sufficient for a free-standing wood burning stove.

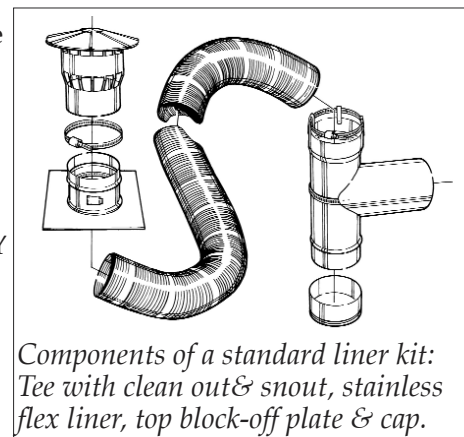

## FLOOR PROTECTION REQUIREMENTS

Your Woodstock Soapstone stove must be set on an approved hearth or floor protection. The hearth protects your floor from two hazards:

- Heat Transfer: Heat radiation from the bottom, front, and sides of the woodstove
- Ember Protection: Sparks and hot coals that may fall out during ash removal and reloading of firewood

**DO NOT INSTALL YOUR WOODSTOCK SOAPSTONE STOVE ON A COMBUSTIBLE SURFACE (WOOD, CARPET, LAMINATE, OR VINYL, FOR EXAMPLE).**

Even if you have a stone or tile overlay on wood, it is still considered combustible since the surface materials will not provide adequate heat transfer protection.

Your stove **MUST** sit on one of the following:

- A hearth pad of solid masonry (brick or tile on concrete and mortared in place)
- A prefabricated hearth pad listed to UL approved standards. These pads are made to be placed on an existing floor. Woodstock Soapstone Company has a good selection of these pre-made pads.
- A custom designed pad constructed of approved non-combustible materials which will protect the floor from sparks, hot coals, and ashes; and prevents heat from being transferred onto the floor beneath.

**IF YOU CHOOSE TO BUILD YOUR OWN HEARTH PAD**

1) Start with a plywood base or sub-floor.

*Over this apply:*

2) a layer of insulating board with an R-Value of at least **0.80** (R value can be reduced by using the optional 3.5" ash lip)\*. Depending on the material you choose, the insulating board can be as little as 1/2" thick. For additional help with material specifications, contact Woodstock Soapstone Company at 1-800-866-4344 or at info@woodstove.com.

*Over this apply:*

3) 1/4" or greater of a decorative, non-combustible material such as tile, slate, stone, or brick. Use mortar or grout to set the material in place, then grout the seams.

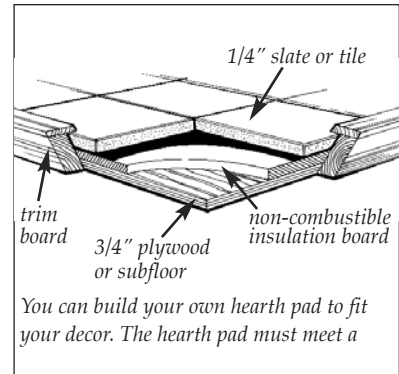

**R-values of common hearth materials:**

Ceramic Tile	1/4"	0.020
Granite	1/4"	0.020
Slate	1/4"	0.025
Cement Mortar	1/2"	0.025
Cementboard	1/4"-1/2"	0.20-0.39
Common Brick	2.25"	0.450
Common Brick	4.00"	0.800

***Please Note:*** Always check with the manufacturer of the hearth material used to verify the R or K value.

K Values cannot be added, convert to R value before adding multiple layers.

**\*The R Value of the hearth pad can be reduced down to 0.40 with the use of the Progress Hybrid Ash Lip EXCEPT WHEN USING THE SHORT LEGS.**

Specifications for floor protectors may be listed in terms of R-value, K-value, or C-value. To convert K or C value to R-value use the following formulas.

K to R:  $R=1/K \times T$  (Thickness of the alternate material)

C to R:  $R=1/C$

Once alternate materials have been converted to R-values, the values of multiple layers can be added to determine the combined protection. If the overall R-value meets or exceeds the specified .80 (or .40) then the materials are acceptable.

**DO NOT USE:** Old-fashioned stove boards that were commonly sold in hardware stores as they **DO NOT** have adequate protection and **ARE NOT** approved for primary floor protection under your stove.

Hearth Rugs also **ARE NOT** meant to be used as primary hearth protection. These are made to be used in addition to an approved hearth, and are used as auxiliary decorative protection. They are not made to be a substitute for an approved hearth pad.

## Hearth Sizing:

Clearances for your 209 Progress Hybrid stove on the front, back and sides must be taken into consideration when determining the placement and size of your floor protection. Vertical dimensions can be added to horizontal dimensions on all but the loading door side to equal the clearances needed to a combustible floor surface. For example, if you are required to have 12 inches in front of the stove for clearance and you have a raised hearth that measures 6 inches high, the stove can sit 6 inches from the edge to equal the 12 inches required. The floor protection must extend under any horizontal connector pipe and 2 inches beyond each side.

### STOVE WITH 10" LEGS

- A. Floor protection in front of stove = 12" **-OR-** With optional ash lip= 8"
- B. Floor protection at loading door side = 16"
- C. Floor protection non-loading door side = 8"
- D. Floor protection behind stove (top vent or rear vent) = 6"

Minimum hearth size in a parallel installation is

43"D x 54.5"W. (10" Legs & NO Ash Lip) **-or-** 39"D x 54.5"W (10" Legs with Front Ash Lip)

47" D x 54.5" W (Short Legs)

Recommended size is 48" D x 60"W or larger (10" legs or short legs with ash lip)

### STOVE WITH SHORT LEG OPTION (Requires ash lip)

- A. Floor protection in front of stove = 16"
- B. Floor protection at loading door side= 16"
- C. Floor protection at non-loading door side = 8"
- D. Floor protection behind the stove = 6"

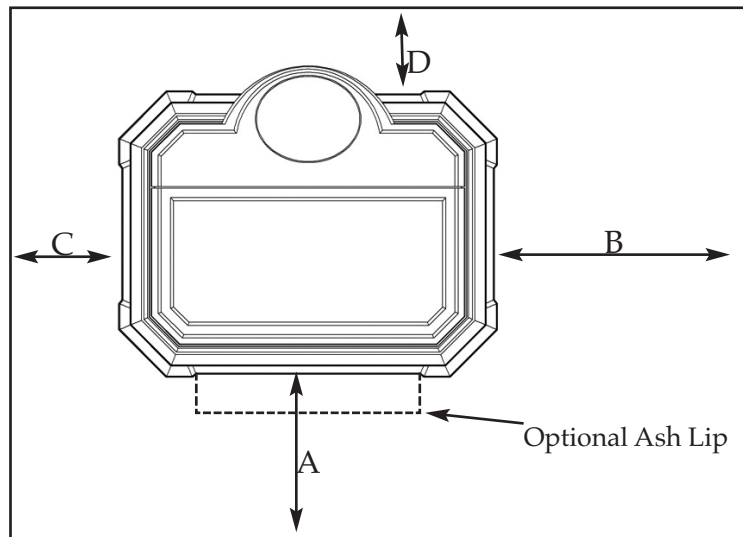

PARALLEL HEARTH PAD

## CORNER HEARTH PAD

Minimum hearth size in a corner installation must be 54"x54" (with the front corner cut off). **NOTE:** On a hearth of minimum size, the stove will not be centered left to right, but will meet the minimum required clearances.

Calculating a Corner Hearth Pad (per NFPA 211):

$A = C \times 1.414 + W/2 + D + \text{Front Hearth Requirement}$

A = distance from corner to the front of the hearth pad

C = clearance from rear corner of appliance to wall (12" w/ rear heat shield)

1.414 = a constant

W/2 = one half the width (15.25")

D = appliance depth (25")

Front Hearth Clearance = 12"

Example:

Progress with the Rear Heat Shield & Pipe Shield

$A = 12" \times 1.414 + 15.25 + 25" + 12" \quad A = 69"$

Note: If using the optional Ash Lip  $A = 65"$

If using the optional Short legs and Ash Lip  $A = 73"$

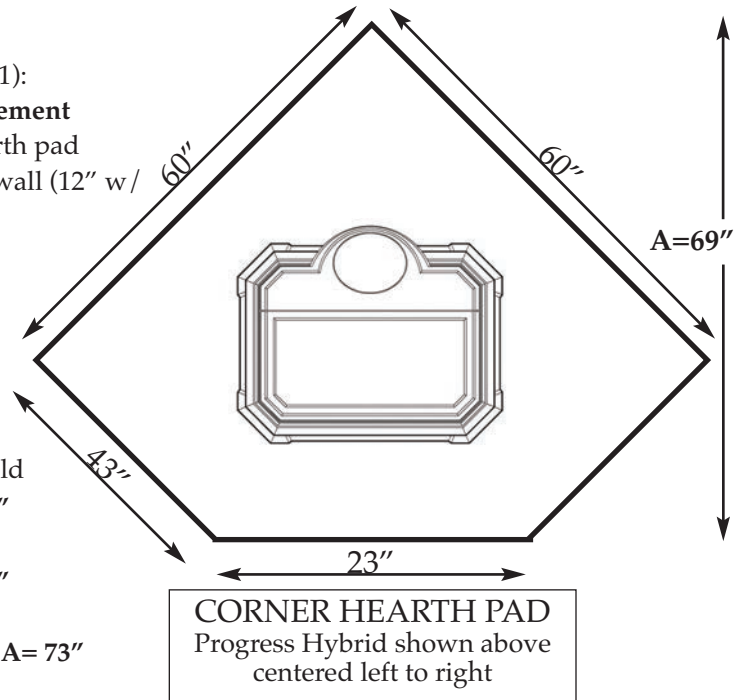

## WALL PROTECTION

The Model 209 Progress Hybrid stove has been tested to UL standards for clearances to combustible walls. The minimum clearances to unprotected walls are as follows:

Minimum clearances with no heat shields to unprotected combustible walls:

From the back-----36"

From the sides-----24"

**Do not assume that a wall is not combustible because it has a nonflammable surface.** A wall with any combustible materials in it must be considered combustible. For example, a brick wall attached to wood studs is considered a combustible wall. Over time, heat will pass through bricks and heat the wood, lowering the ignition temperature of the studs, possibly resulting in a fire. As waves of radiant heat energy meet a combustible object, heat is absorbed and the temperature of the object is raised, which can result in spontaneous combustion. Similarly, wood-framed walls which are covered with tile, stone or fire-rated sheetrock must be considered combustible. Fire-rated sheetrock is also considered combustible due to the paper covering. If you wish to install your stove closer to a combustible wall than standard clearances will permit, you can either attach a UL approved stove & pipe shield, or mount a protective non-combustible shield on the wall.

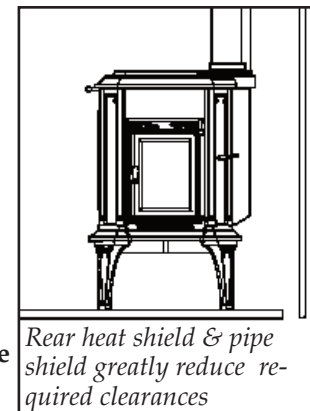

## Stove and Pipe Shields:

Clearances can be reduced by attaching a UL approved heat shield and pipe shield. Woodstock Soapstone Company carries heat shields specifically designed for this stove. When using one or both of these shields, **clearance is measured from the back of the shield to the combustible wall.** The clearance behind the stove can be reduced to 7 inches. The clearance behind the pipe can be reduced to 6 inches.

## Wall shields:

Clearances can also be reduced by mounting a ventilated shield on the wall that extends 36" out beyond the stove (see diagram below). If you are installing wall protection, it should be spaced out from the wall one inch. This air space allows air to flow freely behind the shield, cooling the combustible wall and preventing a pocket of hot air from being trapped behind the shield. The wall protection can be attached to the studs using long screws and ceramic wall spacers. The spacers should not be installed directly behind the stove. The top and either a.) both sides, or b.) the bottom must be left open for adequate ventilation.

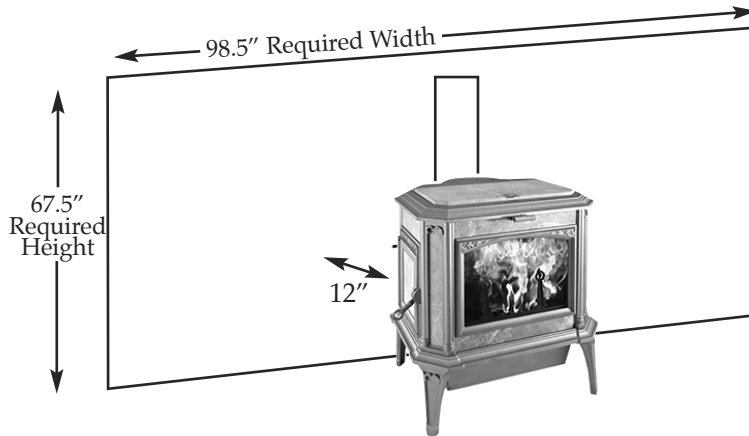

EXAMPLE:  
Wall shield sizing with the 12" Minimum Clearance to Combustible Wall/Top Venting.  
Note: Wall shield size will vary depending on distance between stove and wall.

## Clearance Table For Model 209 PROGRESS Hybrid

Type of Installation▶  Type of protection▼	Top Vent Clearance from stove back and pipe, which goes straight up	Rear Vent Clearance from stove back and pipe, which goes straight back	Rear Vent with elbow Clearance from stove back and vertical single wall connector pipe		Stove Sides
			Stove Back	Stovepipe	
No Protection	36"	36"	36"	18"	24"
3 1/2" thick Masonry Against Combustible Wall*	24"	24"	24"	12"	16"
3 1/2" thick Masonry with 1" ventilated airspace*	12"	12"	18"	9"	12"
24 ga. sheet metal with 1" ventilated airspace*	12"	12"	18"	9"	12"
1/2" thick non-combustible insulation board with 1" airspace*	12"	12"	18"	9"	12"
UL Listed Rear Heat Shield and 36" Vertical Stack Shield	6" pipe 7" stove	7" stove	16"	6"	24"

\*These clearances meet or exceed requirements of NFPA 211, Standard for Chimneys, Fireplaces, Vents, and Solid Fuel Burning Appliances.

- These clearances apply to walls, ceilings, furniture and other combustibles.
- The 36" Vertical Stack Shield attaches to the back of the stove pipe and prevents excess heat from being radiated from the pipe. Heat shield protection is only required for the first 36" of vertical connector pipe.
- At least 30" is required from the front of the stove to combustibles (such as curtains, wall hangings, and furniture).

The same clearances from your stove and stove pipe apply to both fireplace and freestanding installations. Be particularly careful to check clearances to a wood mantel or a wood fireplace facade. You must maintain a 30" clearance to an unprotected wood mantel. See Fireplace Installations on Pages 5-6.

CLEARANCE INSTALLATION DIAGRAMS

**1) Parallel Installation, Single Wall Pipe, Top Vent**

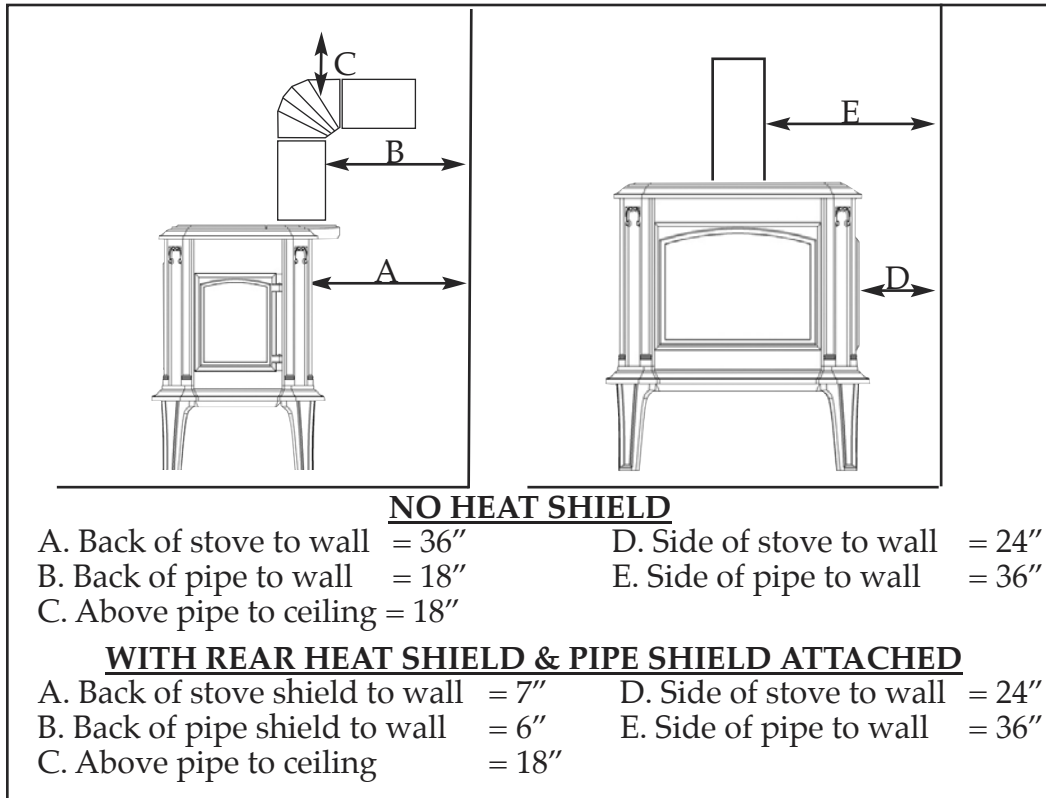

**2) Parallel Installation, Single Wall Pipe, Back Vent**

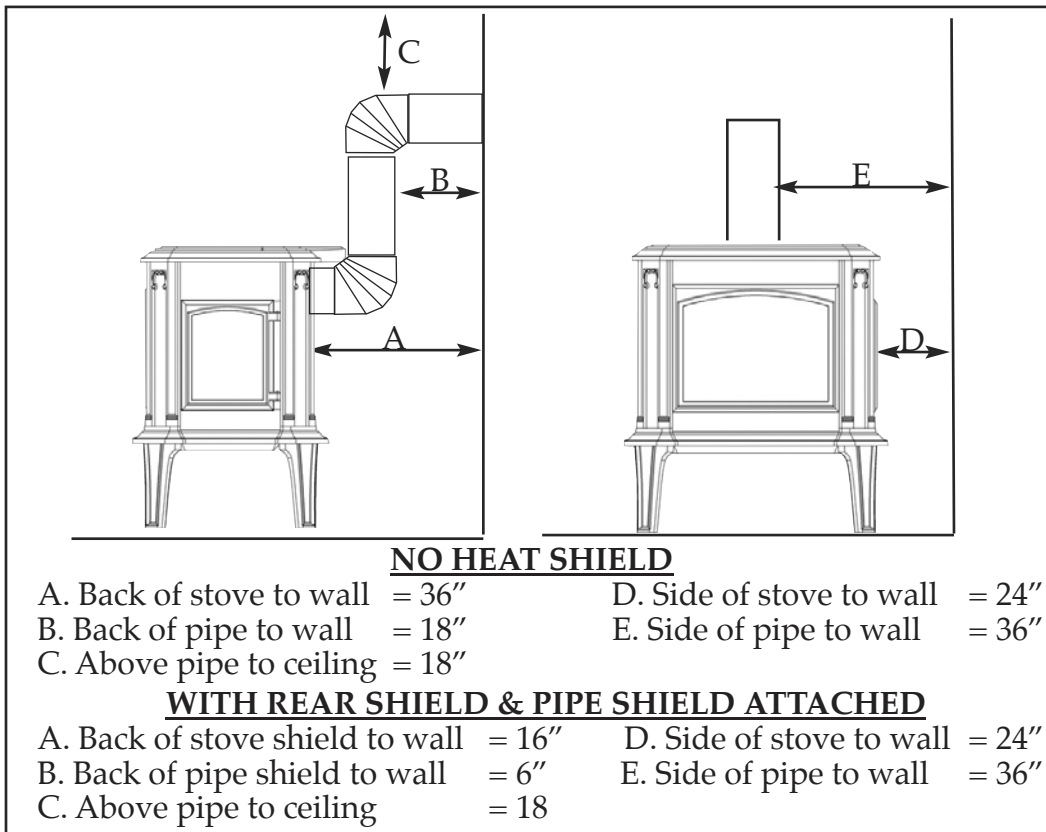



CLEARANCE INSTALLATION DIAGRAMS

**3) Corner Installation, Single Wall Pipe, Top Vent**

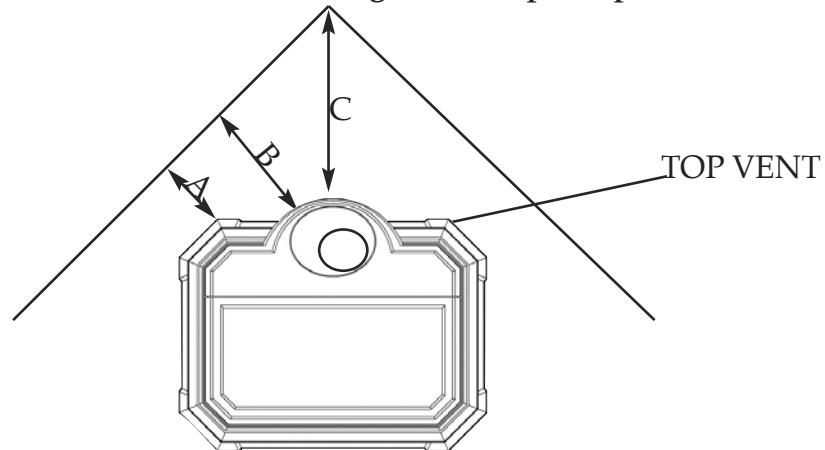

**NO HEAT SHIELD**

- A. Stove corners to side walls = 36" (determines placement)
- B. Pipe to side walls = 18"
- C. Pipe to corner = 18"

**WITH REAR HEAT SHIELD & PIPE SHIELD ATTACHED**

- A. Stove corners to side walls = 12" (determines placement)
- B. Pipe to side walls = 18"
- C. Pipe to corner = 12"

**4) Corner Installation, Single Wall Pipe, Back Vent**

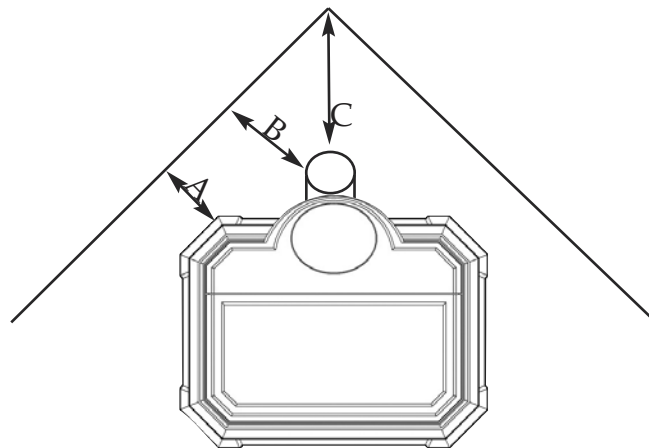

**NO HEAT SHIELD**

- A. Stove corners to side walls = 36" (determines placement)
- B. Pipe to side walls = 18"
- C. Pipe to corner = 18"

**WITH REAR SHIELD & PIPE SHIELD ATTACHED**

- A. Stove corners to side walls = 12" (determines placement)
- B. Back of pipe shield to side walls = 6"
- C. Pipe to corner = 6"

# SETTING UP YOUR STOVE

Your Model 209 Progress Hybrid Wood stove has been shipped fully assembled except for five parts: 1) The stove legs 2) A. The bottom heat shield (if no ash pan) or B. Optional ash pan 3) The flue collar/cover plate 4) Loading door handle.

## (1) How to install the legs:

1) The Progress legs are packed inside of the stove along with step by step instructions and mounting hardware. Remove them from the packaging and read through the instructions. The legs must be installed on your stove prior to use.

2). Remove the outer pallet extensions to access the the pre-drilled mounting holes in the stove base.

3) Hold the leg in position and start the bolt and washer by hand. Tighten with a 9/16" socket or wrench.

4) Repeat step three for all of the legs. Confirm that all of the legs are firmly tightened.

5) Follow the instructions for removing the stove from the pallet once the legs are installed.

**Note:** Use the same procedure to install the optional short legs if needed.

## (2a.) How to attach the Progress fill plate, retainer plate, and bottom heat shield (no ash pan model):

The bottom heat shield prevents excess heat from being radiated from the stove onto the hearth. Illustrated instructions and hardware will be packed with your bottom heat shield. (Refer to the diagram on page 34)

1. Install the firebox fill plate. The top side has several rows of wavy lines. Be sure it lies flat and is evenly spaced front to back and side to side. It is held in place by the retainer plate.

2. Hold the retainer plate up to the base of the stove. There are twelve holes in the retainer plate that align with six holes in the base casting and six holes in the fill plate. Align the holes and secure the retainer plate to the base and fill plate.

3. Secure the bottom heat shield to the base with the bolts provided. An attachment illustration is provided with the heat shield.

## (2b.) How to attach the Progress ash pan:

1. Illustrated instructions and hardware will be packed in your ash pan. Read through them before you begin. (Refer to the diagram on page 35) Install the ash grate. Be sure it lies flat and is evenly spaced front to back and side to side.

2. Next install the ash pan holder. The mounting holes are located on the outer perimeter of the gasket channel under the stove. Be sure your ash pan door is at the same end of the stove as the loading door, line up the holes in the ash pan holder to the corresponding holes on the base of the stove. Tighten the bolts gradually and evenly.

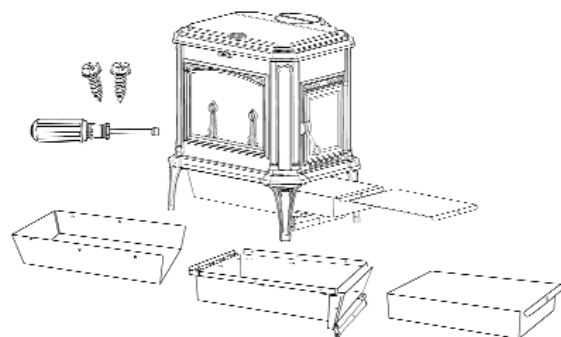

**MAKE SURE THE HOLDER IS COMPLETELY SEATED IN THE GASKET TO PREVENT AIR LEAKS!**

3. Attach the ash pan heat shield and shield extensions to the ash pan holder. The open end of the heat shield accommodates the ash pan door. Line up the holes in the heat shield with the holes in the shield extensions and the holes in the rails of the ash pan holder. Secure with provided sheet metal screws.

4. Open ash pan door and slide the ash pan into the holder. **REMOVE THE ASH PAN COVER BEFORE LIGHTING YOUR STOVE.**

### (3) How to attach the Progress flue collar & cover plate:

Your Progress Hybrid will arrive with the flue collar pre-installed on the rear exit and the cover plate on top of the stove. The flue collar and cover plate are interchangeable. If you prefer to top vent your stove, please follow the steps below.

#### Top Venting:

1. First, reach in through the back flue collar and remove the 2 bolts and washers that secure the cover plate to the stove. With the top cover plate removed, reach in and remove the 2 bolts and washers that secure the flue collar to the back of the stove.

2. Next, install the cover plate on the back exit of the stove. Hold the cover plate over the flue exit that will not be used. Line up the holes of the cover plate with the tabs located to the right and left of the flue exit. Place a flat washer over one of the bolts provided and thread it into the hole in the cover plate. Thread the second bolt and washer through the other tab into the cover plate. Tighten the bolts.

3. Place the flue collar over the top flue exit. Be sure it is seated in the gasket.

4. Line up the holes in the flue collar with the tabs to the right and left of the flue exit. Secure flue collar with the remaining bolts and washers. Tighten the bolts.

5. Do not overtighten these bolts: simply tighten until each is firmly seated in the gasket and the bolts are snug.

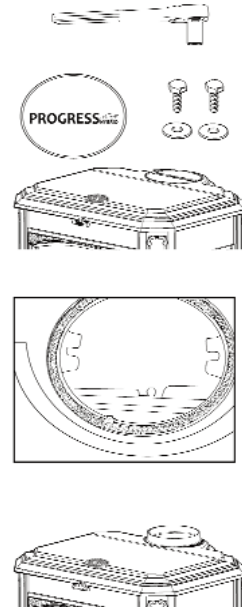

### (4) How to install the load door handle:

1) The door handle assembly consists of a threaded ring and a spacer. Detailed instructions are packed with the parts.

2) Thread the rod into the door latch.

3) Slide and hold the spacer over the rod.

4) Turn the ring onto the threaded hole already attached to the loading door. The ring should be tight in the vertical position.

# OPERATION

## Seasoning Your Stove

Both soapstone and cast iron need to be seasoned. The seasoning can be accomplished through a series of small to moderate fires. Your Woodstock Soapstone Stove is an easy stove to season, because even a small fire will provide hours of radiant heat once the stove is warm. **There are two things you will notice during the first fire:**

**First, there will be a hot, acrid smell as the stove heats up.** This smell is a result of the paint on the cast iron curing. You will want to have your first fire on a day when you can open the windows in the house to provide adequate ventilation. The odor is non-toxic and will only be present for the first few fires.

**Second, there will be some condensation on the glass.** This condensation is a result of moisture being driven out of the furnace cement in the stove and condensing on the inner surface of the glass. It takes a couple of small fires to season the stove and remove this excess moisture.

After the first few fires, the texture and grain of the stone may become slightly more pronounced, and the color may deepen a shade.

## Starting a Fire And Establishing Proper Draft

1. Open the catalytic bypass. Turn the bypass handle clockwise to open the bypass door. It will stop when the bypass is fully open. (Fig. 1)

2. Open the combustion air damper by lowering the damper lever all the way down to the full open position. With the lever in the down position, maximum air is allowed into the firebox. (Fig. 2)

3. **Always confirm there is adequate draft before lighting the fire.** Hold a lit match or light a small piece of newspaper in the top of the firebox, where smoke exits. If the flame is drawn out of the firebox, toward the flue, proceed with lighting the fire. If the flame stands still or is pushed away from the flue exit, you must establish a good draft before lighting a fire. A hair dryer or heat gun pointed at the flue exit is a good way to establish draft without creating a lot of smoke. After you think you have draft, re-test with a match.

4. Once good draft has been established, build a fire on the floor of the firebox. Do not use additional grates, andirons or any other methods to support the fuel in the firebox. Start with crumpled newspaper and dry kindling.

5. Add small splits of firewood once the kindling has ignited. This will establish a bed of hot coals.

6. Add small to medium splits onto the hot coals. Assuming the wood is dry, the fire should spread through the wood. After about 10 minutes, close the air damper about half way between fully open (all the way down) and fully closed (all the way up).

7. After the stove top temperature reaches 250°F or your single wall pipe temperature reaches 300-350°F, close the bypass by turning the handle counter clockwise into the closed position. It will stop when the bypass is fully closed. All of the smoke from the firebox will now pass through the catalytic combustor. The combustor will generate a substantial amount of heat as it “burns” the smoke passing through it.

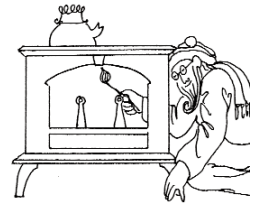

Use your bypass handle to engage or disengage your catalytic combustor. (Fig 1)



The amount of combustion air available in the firebox is controlled by the damper lever. (Fig 2)

8. Adjust the air control damper to a lower setting by lifting the lever up. The lower the burn rate, as less air is entering the firebox. The final damper setting will be determined by the desired heat output from the stove, the condition of the wood being burned, and the draft through the chimney system.

**CAUTION**  
NEVER USE GASOLINE, GASOLINE TYPE LANTERN FUEL, KEROSENE, CHARCOAL LIGHTER FLUID OR SIMILAR LIQUIDS TO START OR "FRESHEN UP" A FIRE IN THIS STOVE. KEEP ALL SUCH LIQUIDS WELL AWAY FROM THE STOVE WHILE IT IS IN USE.

## Engaging the Catalytic Combustor

The catalytic combustor will start to burn the gases and particles in the smoke when the temperature of the smoke reaches approximately 500°F, or after about 10-15 minutes of establishing a strong fire. Each stove comes with a surface thermometer and a probe thermometer. Use the surface thermometer to monitor stove surface temperatures. The temperature on top of the stove is approximately 1/2 the temperature inside the stove, so when the thermometer on the stove top reads 250°F, it is 500°F inside. You will find that after the combustor is engaged, surface temperatures will often rise considerably- evidence that the combustor is producing lots of heat! The probe thermometer reads the temperature just one inch downstream from the exit face of the catalyst.

Engage the combustor by turning the bypass handle (front of the stove) counter clockwise until it clicks into its position. Then reduce the air damper to achieve the desired burn rate. Make fine adjustments to your air control damper by moving it slightly up or down. You may find that you can achieve the longest burn when the damper is only slightly open. In the Progress Hybrid, allowance is made for a small amount of primary and secondary air to enter the stove even when the damper is fully closed, and the stainless steel catalyst will work efficiently at low to moderate firing rates, thus preventing creosote formation or excessive smoke from your chimney.

## Low & Overnight Burning

These instructions are intended as a guide to operating your wood stove. Your timing and final damper settings will vary depending on chimney draft, type of wood, moisture content of the wood and size of the splits. The Progress Hybrid is simply designed and intended to be user friendly, but it will take some practice to get used to it.

1. Before you open the loading door, you must fully open the catalytic bypass and the air damper. Wait a minute or so for a strong draft to be established to prevent smoke from spilling back into the room.
2. Stir up the hot coals. If necessary, excess ash should be removed before reloading the firebox. If your stove has the optional ash pan, simply rake the hot coals back and forth in the firebox to allow the loose ash to fall through the grate into the ash pan. If your stove does not have an ash pan, push the hot coals to one side and shovel the loose ash into a non-combustible ash container with a tight fitting lid. Dispose of the ash properly.  
**Never put an ash container on a combustible surface, like a wood floor.**
3. Place several small splits on top of the hot coals and allow them to ignite.
4. Load the firebox to capacity leaving space for secondary combustion, with a mix of larger and smaller splits. Close the loading door.
5. Adjust the air damper to its the low burn setting by raising the lever up to reduce the air flow, generally around the last big notch.(fig 3).
6. Close the catalytic bypass, by turning the handle counter-clockwise until it stops.
7. Initially the fire may appear to die out. This may cause a small amount of soot to collect on the glass. Any buildup on the glass should go away with higher temperature burns.



Lower Air Damper Setting (fig 3)

**Never burn the stove with the air damper fully open except when kindling a fire or reloading the firebox.**

Never build a roaring fire in a cold stove. It takes at least 30 minutes to heat the soapstone panels of the Progress.

Attempts to reach high temperatures very quickly could result in damage to the cast iron or soapstone parts.

## Burning for Higher Heat Output

These instructions are intended as a guide to operating your wood stove. Your timing and final damper settings will vary. The Progress Hybrid is simply designed and intended to be user friendly, but it will take some practice to get used to it.

1. Before you open the loading door, you must fully open the catalytic bypass and the air damper. Wait a minute or so to establish a strong draft. This will help to keep smoke from spilling into the room.
2. Stir up the coals and remove excess ash as needed.
3. Place several small splits on top of the hot coals and allow them to ignite.
4. Load the firebox to capacity leaving space for secondary combustion, with a mix of larger and smaller splits. Close the loading door.
5. Allow the fresh wood to become involved in the fire. With dry wood this may take 5-10 minutes. Lift the air damper up to the close approximately half way.
6. Close the catalytic bypass by turning the bypass handle counterclockwise until it stops.
7. You should see the flames from secondary combustion at the top rear of the firebox becoming more active. Adjust the air damper to approximately one quarter open.

## Ash Removal

**NEVER BURN THE STOVE WITH THE ASH DOOR OPEN!**

### **Without an ash pan:**

If your Progress Hybrid does not have an ash pan you will have to remove ash through the side door, approximately every 5-7 days if the stove is in continuous operation. You do not have to let the fire die out completely to remove the ashes, but the fire must be reduced to hot coals. First make sure that both the catalytic bypass damper and the air control damper are open. This will increase the draft and prevent smoke from entering the room.

Open the side door and move the hot coals to one side of the firebox. Scoop out the ashes that were underneath the coals, and then reverse the procedure. Leave some ash and hot coals in the bottom of the stove to help rekindle a fire.

### **With an ash pan:**

If your Progress Hybrid is in continuous operation, you will probably need to empty the ash pan every 7-10 days. You do not have to let the fire die out completely, but make sure that it is reduced to hot coals. Open the catalytic bypass damper, and open the air control damper. Remember to wear stove gloves - the ash pan will be hot! Open the ash pan door located below the loading door. Carefully slide the lid into place on the top of the ash pan and remove the ash pan from the base of the stove. The lid slides over the long top edges of the ash pan. Close the ash pan door before emptying the ashes into an appropriate container.

Do not open the ash removal door while the stove is in the middle of a long burn, because the additional draft created under the fire could cause the stove to burn excessively hot and the ash pan itself will be very hot, and full of live coals. If you are burning your stove 24 hours/day, it is often easiest to empty the ashes first thing in the morning, after an overnight burn.

Ashes should be emptied into a metal container with a tight-fitting lid. The closed container of ashes should be placed on a noncombustible floor or on the ground, well away from all combustible materials, pending final disposal. If the ashes are disposed of by burial in soil or otherwise locally dispersed, they should be retained in the closed container until all cinders have thoroughly cooled. Live cinders can

take up to 36 hours to cool. Woodstock Soapstone Company offers a black metal ash holder with a hinged lid that closes tightly. Four sturdy legs keep it off the floor, and the wooden handle is not only decorative, it will also protect your hands.

**Never shovel ashes into a combustible container like a cardboard box or a plastic bucket. Do not use a vacuum cleaner to remove ashes unless it is specifically designed for woodstove ash removal. Do not ever leave a container of hot ashes on a wood floor or porch.**

## The Surface Thermometer and Probe Thermometer

We recommend placing the thermometer 8"-10" above the flue collar on **single wall** stove pipe if the stove is vented out the top. If the stove is rear vented, the surface thermometer should be placed on the cast iron cover plate toward the back of the stove. If you are reading the single wall stove pipe temperature, the interior flue exhaust temperature is about twice as hot. Since the 22 gauge sheet metal pipe is more reactive (faster heat transfer) than the stove top, you will find you can engage the combustor sooner. We recommend engaging your catalytic combustor once the pipe thermometer reaches 300°-350° F. Stove top temperatures should reach approximately 250°F.

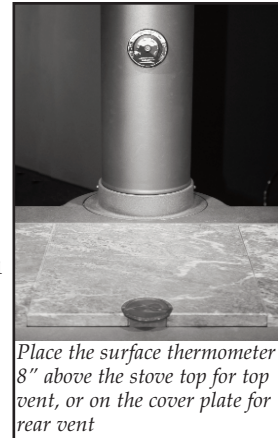

*Place the surface thermometer 8" above the stove top for top vent, or on the cover plate for rear vent*

Once the combustor is engaged, you should see the stove surface temperature rise and the pipe temperature drop, indicating catalytic combustor activity. From a cold start it may take 30-45 minutes to get to the stove up to temperature. If you are reloading a hot stove, wait approximately 10-15 minutes before engaging the combustor.

The thermometer is not a precise instrument – it will not tell you the exact temperature inside the firebox or in the flue. If reading the surface temperature the thermometer will not register changes in temperature quickly due to the thickness and heat retention of soapstone. We supply the thermometer to give you some idea of what is going on inside the stove, and to provide a guide for operation.

<u>STOVE TOP READING</u>	<u>OPERATION</u>
over 300°.....	OK to engage the combustor
400-600°.....	Normal operating temperature
600-700°.....	High burn range
over 700°.....	DO NOT burn in this range

The probe thermometer can be inserted into the port beside the flue collar in the rear of the stove. The probe thermometer will measure the temperature immediately downstream of the catalytic combustor. The sensing end of the probe extends to within 1 inch of the face of the catalyst. The probe is calibrated from room temperature to 1700 degrees F. The catalyst can be engaged as soon as the temperature on this probe exceeds 500 degrees F, or as soon as the temperature on the pipe thermometer exceeds 250 degrees (see above). The best operating range for the catalyst is from 500 - 1400 degrees F. When the temperature on the probe thermometer exceeds 1400°F, we recommend closing the damper to prevent excessive heat from occurring

## Overfiring

The cast iron parts in your Woodstock Soapstone Stove are of the finest quality. Our cast iron parts have been made in the same foundry since the mid 1980's, and the foundry itself has been in business for over one hundred years. Each cast iron part is inspected by our stove builders before it becomes part of a stove. However, cast iron is not indestructible. Experts have shown that cast iron begins to oxidize (reddish or whitish discoloration) at 1400° F. Burning a stove frequently at excessive temperatures is known as overfiring. When the surface temperature is consistently over 700° F, the stove has reached 1400° F inside. Operation with temperatures in this range can lead to cast iron warping, becoming brittle, and eventually deteriorating completely. It can shorten the useful life of the catalytic combustor.

**DO NOT OVERFIRE!**  
**ATTEMPTS TO ACHIEVE HEAT OUTPUT RATES THAT EXCEED STOVE DESIGN SPECIFICATIONS CAN RESULT IN PERMANENT DAMAGE TO THE STOVE AND TO THE CATALYTIC COMBUSTOR.**

Avoid overfiring by letting the combustor and secondaries do most of the work in the stove. Your stove is operating at peak efficiency when the combustor is "engaged" and the secondaries are ignited, with the damper lever set to a low to moderate setting, and the logs are glowing with secondary flames apparent. You will get the greatest amount of heat per pound of wood when the stove is operated in this manner.

## Daily Use

Your Progress stove is well-suited for continuous firing on a 24 hour-a-day basis. It will burn for hours on one load of wood, and will provide steady, even heat for hours after the fire dies down. One of the qualities of soapstone most enjoyed by wood burners is its ability to absorb heat and then to release the heat evenly. When the temperature on top of the stove drops below 250°F during an all-night burn, it is not necessary to disengage the combustor. You need only disengage the catalytic combustor when you kindle a fire, or reload the stove. Once the catalyst is ignited, it will continue to function as long as there is smoke to burn. This is true even if the surface temperature on top of the stove drops below 250°F at the end of a long burn.

Your connector pipe and chimney or chimney pipe should be inspected at regular intervals (not less than once every two months). Examine the connector pipe for creosote, corrosion, loose seams, or excessive soot. Clean and replace as necessary. The chimney or chimney pipe should be cleaned and checked by a certified specialist once a year. A small mirror held at the cleanout door of a masonry chimney will be helpful. For a class A prefabricated metal pipe, some disassembly is usually required.

## The Fall-Away Handle

The "fall-away" handle, which comes with your stove, can be used to operate the side door latch or the catalytic bypass damper. Simply insert the round knob end of the Fall-Away Handle into the door pull ring to open/close, or latch/unlatch the loading door. The loading door and the pull ring and the catalytic bypass handle are very hot, so use the tool provided. The "fall-away" handle conforms to UL requirements and is made so that if you let go of it, it will "fall-away" from the stove and not become too hot to handle.



*The fall-away handle may be used to operate the controls on your stove when they are too hot to handle safely.*

## The Progress Cook Top

The top lid of the Progress wood stove consists of a three-piece stone set and a cast iron plate below. The lid has been designed to enhance the beauty and versatility of your stove. The soapstone serves to provide long lasting radiant heat as well as the perfect cooking surface for foods to simmer over moderate heat for longer periods. The stone panels can be raised individually or collectively to expose the cast iron cook top underneath. The cook top has three distinct areas that provide high, medium, and low temperature zones for more cooking flexibility. The center "burner" is flush and delivers the highest heat. The left is elevated about 1/16" and provides medium heat. The right is raised 1/8" and has the lowest temperature. In general, if the temperature on the stone is 300°-350° the center of the cast iron cook top is 500°-550°. The temperature drops approximately 50° per 1/16" of height, so the left burner would be 50° cooler than the center and the right burner 100° cooler. The cast iron cook top is not designed as a cooking surface and food should always be placed in a heavy duty Dutch oven or skillet, not directly onto the cast iron.

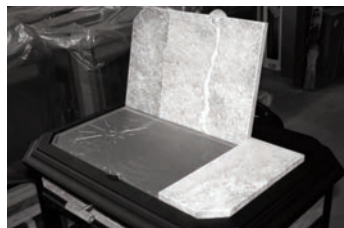

The stones can be removed completely from the stove, and the cast iron cook top will stand upright in the rear channel to access the catalytic combustor below. This easy access makes cleaning and replacing the combustor very user friendly.



# Firewood

Your Woodstock Soapstone Stove is designed to burn seasoned, natural cordwood. Higher efficiency and lower emissions generally result when burning air-dried seasoned hard woods, as compared to green, freshly cut hard woods. It is perfectly fine to burn soft woods in your stove as long as they are properly dried. Hard woods are preferable because they are typically denser than soft woods which gives them a higher fuel value.

The moisture content of some trees may range as high as 50% – i.e., there is as much moisture in the tree as there is wood. After wood has been stored for a year, the moisture content will usually range from 15-25%. Splitting wood before it is stored will reduce drying time. Properly dried wood will produce more heat, reduce the likelihood of water vapor condensing in the chimney forming creosote, and result in less pollution entering the air. It is safer and more efficient to burn dry or seasoned hardwood than green or wet wood that smolders.

The advantages of burning dry wood are many. Dry wood is lighter, easier to split and easier to carry. It is easier to light, produces more heat and generates less pollution. If you burn wet wood some of the energy generated by the fire is used to drive moisture out of the wood, rather than producing heat for you. Dry wood will maintain the highest combustor temperatures and burn the most efficiently. Creosote is much less likely to form if you burn dry wood.

**DO NOT BURN** treated or painted wood, coal, garbage, cardboard, solvents, colored paper, or trash in your Woodstock Soapstone Stove. Coal and artificial logs burn much hotter than wood and could cause damage through overheating to the cast iron or the soapstone panels. Burning treated wood, garbage, solvents, colored paper or trash may result in the release of toxic fumes and may poison or otherwise render the catalytic combustor ineffective.

Burning cardboard, loose paper, and trash will add significantly to ash and soot build-up, and it will not produce much heat. Fly ash from improper fuel can also coat or plug the screens and combustor, causing smoke spillage into the room. Under normal operating conditions, the Woodstock Soapstone Stove is designed to last for generations. It is not, however, designed for continuous over-firing, or firing with coal, artificial logs or trash.

- |  |
|--|
| <p><b>DO NOT BURN</b></p> <ul style="list-style-type: none"><li>• Treated Wood</li><li>• Coal</li><li>• Garbage</li><li>• Cardboard</li><li>• Solvents</li><li>• Colored Paper</li><li>• Trash</li></ul> |
|--|

<p style="text-align: center;"><b><u>CAUTION</u></b></p> <p><b>NEVER USE GASOLINE, LANTERN FUEL, KEROSENE, CHARCOAL LIGHTER FLUID, OR SIMILAR LIQUIDS, TO START OR 'FRESHEN UP' A FIRE IN THIS STOVE. KEEP ALL SUCH LIQUIDS WELL AWAY FROM THE STOVE WHILE IT IS IN USE.</b></p>
--

# CATALYTIC COMBUSTORS

Here is how your catalytic combustor works.

The catalytic combustor is a stainless steel honeycomb with hundreds of cells. If you looked at the inside of each cell with a microscope, you would see that the walls are uneven and filled with minute nooks and crannies. Precious metals, such as platinum, are sprayed on the inside of these cells to coat all of the nooks and crannies. This creates the largest possible surface area to interact with the wood smoke. The catalytic combustor in your stove is very similar to the one in the exhaust system of your automobile and works to achieve the same results - high efficiency and clean air!

When you first start a fire, you should bypass your catalytic combustor and let the smoke go directly up the chimney. Once wood smoke reaches 500° F (about 10-15 minutes after re-establishing a strong fire), it is hot enough to ignite the catalytic combustor. As the wood smoke passes through the cells in the combustor, the smoke reacts with the precious metals which line the inside of the honeycomb and both combustible gases and particles in the smoke ignite and burn. This “catalytic burn” reduces emissions and also increases heat output from the stove.

Without a catalytic combustor, between 5% - 40% of the chemical energy contained in wood simply escapes up the chimney when wood is burned. Energy laden gases are exhausted up the chimney where they pollute the air or may condense on the inside of the chimney flue as creosote. The slower the burn, without a catalytic combustor, the greater the amount of energy that is lost. A long smoldering fire is the least efficient use of energy in wood, yet it produces lots of smoke, which is the fuel supply for the catalytic combustor.

Most of the chemical compounds in wood smoke are combustible. The catalyst produces high temperatures, which loosen the bonds of these chemical compounds and “burns” wood smoke. A stove that “burns” these compounds and uses smoke as additional fuel will burn more efficiently and produce more heat, while reducing creosote and air pollution at the same time. However, most stoves cannot consistently produce temperatures high enough to burn cleanly, particularly during long burning times - hence the need for a catalytic combustor.

Your catalytic combustor can get the most efficiency out of every piece of wood if it has three things: temperature, turbulence, and time.

- 1. Temperature.** The catalytic combustor can only start burning the gases in the wood smoke after the smoke has reached at least 500 degrees F. Before the smoke reaches that temperature, it simply is not hot enough to start the reaction at the combustor. This will result in an inefficient smoldering fire.
- 2. Turbulence.** The wood smoke can interact best with the precious metals inside the honeycomb cells if there is some variation in the air flow. Increased turbulence enables more of the wood smoke to come into contact with more of the nooks and crannies in the honeycomb cells. The exhaust path as well as the irregular surface of the combustor cells adds needed turbulence.
- 3. Time.** Once the temperature and turbulence are achieved, the catalytic combustor just needs to have enough time to burn all the gases in the wood smoke. For this reason, it is best to minimize the amount of air you allow into the firebox once the combustor is ignited. Allowing too much air into the firebox speeds up the rate at which the fire burns and allows more wood smoke to be consumed by the secondary combustion system. The ideal air setting for a long catalytic burn allows enough air to keep the wood burning and producing smoke.

With proper care, a new catalytic combustor will give years of fuel savings and lowered emissions. By following some simple guidelines you can ensure maximum combustor performance and longevity. Your catalytic combustor is designed to last for 12,000 -14,000 hours of use. You can ensure yourself of getting the maximum life from your combustor by following these simple guidelines:

- 1) Burn only natural, well-seasoned wood.
- 2) Wait until the exhaust gases reach about 500 degrees F (internal temperature) before engaging the catalytic combustor (about 10-15 minutes after re-establishing a strong fire).
- 3) Bypass the combustor before reloading and leave the bypass open for a few minutes after reloading to raise the temperature in the stove.
- 4) Don't overfire the stove.
- 5) Clean the combustor regularly. See instructions below.

You can also obtain a lot of useful information by visiting our website ([www.woodstove.com](http://www.woodstove.com)). Other very useful web sites on all aspects of wood burning are ([www.hearth.com](http://www.hearth.com)), ([www.woodheat.org](http://www.woodheat.org)) and ([www.csia.org](http://www.csia.org)). CSIA is the Chimney Safety Institute of America.

## Inspection & Cleaning

Your stove comes with a new stainless steel combustor already installed. The stainless combustor is a honeycomb foil block located under the top lid of the Progress. Typical lifespan for a well maintained catalytic combustor is 4-6 years. There are a few ways to determine if your combustor needs to be cleaned. If you notice the smoke exiting your chimney is thicker and darker in color the combustor may need cleaning. Additionally, if you notice reduced draft or backpuffing, or performance and heat output has diminished, then the combustor may not be working as efficiently as designed.



### STANDARD COMBUSTOR CLEANING HOW TO:

**Tools needed:** (1) work gloves and safety glasses; (2) soft bristled paint brush or vacuum cleaner (preferably one designed for ash removal).

1. Be sure the fire is out and the stove is cold. If you are using a regular home vacuum, it is extremely important that no hot ashes or embers be sucked into it as this could result in damage to the vacuum or cause a serious fire. Remove the top stones from the stove. Lift the cast iron cook top and stand it up in the rear channel.

2. Slide the combustor forward and out from under the cast iron surround. Brush or vacuum the combustor thoroughly, from both sides. **Do not** use high pressure compressed air to clean the combustor, as this could damage the reactive coating. Be sure to remove all fly ash from the combustor. Inspect the gasket that the combustor rests against.

3. Slide the combustor back into position. Be sure it is seated firmly against the gasket behind it. Tuck the narrow gasket between the combustor and the cast iron hood that surrounds it to ensure a tight fit.

### VINEGAR & WATER CLEANING HOW TO:

The vinegar & distilled water cleaning is recommended 1-2 times during the heating season. The vinegar is just acidic enough to remove any ash within the cells that may be masking the catalytic coating.

**Materials needed:** (1) work gloves and safety glasses; (2) spray bottle; (3) white vinegar; (4) distilled water.

1. Be sure the fire is out and the stove is cold. Remove the top stones from the stove. Lift the cast iron cook top and stand it up in the rear channel.

2. Slide the combustor forward and out from under the cast iron surround. Place the combustor onto

newspaper or an old towel. In the spray bottle prepare a 50/50 white vinegar & distilled water mixture.

3. Spray the 50/50 mixture through one side of the combustor and allow it to drain onto the newspaper. Flip the combustor over and spray through the other side and allow it to drain.
4. Rinse the combustor with 100% distilled water to remove any remaining vinegar, allow the combustor to dry before returning the combustor to the stove.
5. Return the combustor to the stove. Be sure that it is seated properly to the gasket behind.
6. Close the top lid.

## Catalytic Combustor Replacement

If you feel that your catalytic combustor is not working properly, please contact Woodstock Soapstone Company at 1-800-866-4344 for instructions regarding return and replacement. Accessing the catalyst in your new Progress Hybrid Woodstove is simple, just remove the top soapstone pieces, raise the cast iron cook top, and gently pull the combustor out of its housing. If it is difficult to pull out, there is a small recess on each end of the stainless steel combustor. You can insert a small screwdriver into the hole and pull the combustor forward, first one side and then the other.

## Frequently Asked Questions

### **Q. How does the catalytic combustor work?**

**A.** The catalytic combustor breaks the bonds that hold the chemicals contained in wood smoke together. The result is that these chemicals begin to burn at temperatures of about 500 degrees F (the normal range of exhaust gas temperatures). Without the catalytic combustor, wood smoke would have to be brought up to a temperature of 1000 to 1200 degrees F in order to start to burn. A stove with a catalytic combustor will generate up to 25% more heat from each piece of wood, thus reducing the amount of fuel used during the year.

There are three advantages to burning the smoke created by burning wood. First, the smoke becomes another source of fuel, giving you more heat from the same amount of wood. Second, creosote causing materials will be burned up instead of being deposited in your chimney, reducing the risk of a chimney fire. Third, air pollution will be drastically reduced.

### **Q. How can I tell if the catalytic combustor is working?**

**A. First** - The best way to tell if the catalytic combustor is working is by observing the smoke coming out of your chimney. If there is only a small amount of smoke, and/or it's white in color, the catalytic combustor is working. You will see significantly more smoke when the combustor is being bypassed than when the smoke is being burned by the combustor.

**Second** - One very noticeable effect of a well functioning combustor is the high efficiency of your stove. Catalytic combustors produce lots of heat, which the stove radiates into your home. If you notice that the stove is producing less heat, or that a load of wood doesn't provide as much warmth, under similar circumstances, as it did before, it's time to check the combustor. If and when the catalyst ceases to function properly, the stove will produce noticeably less heat.

**Third** - Regular inspection of the connector pipe and chimney flue should show very little accumulation of soot and creosote. Soot is typically brown and powdery when the combustor is working properly. Heavy buildup of black sticky creosote may indicate the combustor is not functioning or needs cleaning.

### **Q. How do I maintain my catalytic combustor?**

- A. Combustors should be inspected and cleaned if necessary **every 4-6 weeks** during the heating season. When the stove is cool, the combustor can be cleaned by thoroughly vacuuming or brushing both sides.

If the stove does not draft well when the catalytic combustor is engaged, then the combustor cells themselves might be partially plugged with fly ash. If this is the case, follow the cleaning procedure described in detail on page 19 of this manual.

**Q. How will I know if the combustor is “worn out”?**

- A. There are three symptoms that will indicate that the catalyst in your stove may not be working: First, your stove will generate noticeably less heat than it will when the catalyst is working. Second, you will notice a dramatic increase in the amount of soot and/or creosote in your stovepipe or chimney. Third, the color of the smoke produced by the stove will change. Smoke will appear black or brownish, instead of clear, white smoke (almost steam) from a catalytic stove.

If you suspect that your catalyst is not working, let the stove cool down and clean the combustor and try it again.

**Q. Is it all right to burn my stove hot daily to clean any build up in my chimney system?**

- A. It is not necessary to burn your stove hot daily to burn off any creosote build up in the chimney. This function is performed by the catalytic combustor. It is there to reduce the emissions from the stove that contribute to deposits in the connector pipe and chimney flue.

View more frequently asked questions and articles at our web site [www.woodstove.com](http://www.woodstove.com). Other very useful websites on all aspects of wood burning are [www.hearth.com](http://www.hearth.com), [www.woodheat.org](http://www.woodheat.org), and [www.csia.org](http://www.csia.org). CSIA is the Chimney Safety Institute of America.

**TWO OTHER IMPORTANT POINTS REGARDING CATALYTIC COMBUSTORS:**

- 1) The combustor uses wood smoke as fuel. Most smoke is created in the early stages of the burn cycle. When a bed of coals is all that remains of your wood, there is little smoke left to fuel the combustor, and it will no longer create substantial amounts of heat. Hence, the temperatures on the surface thermometer tend to fall toward the end of the burn, even though the firebox is full of hot coals. This does not mean that you have to reload the stove or open the bypass. Let the hot coals burn down to ashes.
- 2) Since the combustor blocks the path of exiting smoke, it can reduce the draft in your stove. When draft is reduced by warm or rainy weather, open the bypass damper longer when starting the stove to create more draft.

**CATALYTIC COMBUSTOR WARRANTY**

The catalytic combustor in your Progress Hybrid Woodstove is fully warranted for three years from the date of purchase against any defect in workmanship or materials that prevent the combustor from functioning when installed and operated properly. The catalytic combustor is additionally warranted for three years from the date of purchase for any deterioration in the stainless steel substrate material. For instructions regarding return or replacement of the catalytic combustor, please contact:

Woodstock Soapstone Company, Inc.  
66 Airpark Road  
West Lebanon, NH 03784  
Phone: 1-800-866-4344 • Web: [www.woodstove.com](http://www.woodstove.com)

# MAINTENANCE

## Stove Cleaning

The ornamental cast iron frame of the Woodstock Soapstone Stove is painted with two coats of high temperature stove paint. Under normal operating conditions, this paint will not peel or blister. We suggest cleaning by dusting with a soft brush or vacuuming with a brush attachment when the stove is cold. If the iron castings are exposed to moisture for a long period of time they may rust. If this happens, brush the affected area until clean with either a short wire brush or medium steel wool and then touch-up with high temperature stove paint, which is available from Woodstock Soapstone Company.

Soapstone is a very soft mineral and the polished exterior surfaces can be scratched. Scratches may be easily removed by sanding lightly with medium steel wool or 120 grit sandpaper. The surface may then be buffed with 400 grit sandpaper or fine steel wool. Remove dust created by sanding with a vacuum cleaner; a damp cloth will simply spread it around. Be sure the stove is cold before you clean it.

## Glass Cleaning

We use ceramic glass in our stoves because it is resistant to both impact and thermal shock. The panes of ceramic glass installed in the stove fronts have full gaskets around the perimeter so there is no contact between the glass and the cast iron frame.

There are two panes of glass at the front of each stove, with an air-space between the two panes. This “thermalpane” arrangement helps keep the temperature on the inside of the glass higher and prevents condensation and soot from accumulating. The Progress Hybrid has a large glass area with an “airwash” design in which the primary air supply washes over the front glass to assist in keeping the glass free of ash and soot.

The glass may soot up the first time you use the stove (from condensation already inside the stove). Don't be alarmed! Usually, as soon as you build up adequate temperature with a hot fire, the glass will clean itself. The residue will burn off, and it will stay clean. Soot accumulation on the inside of the glass is more likely in the spring and fall, when temperatures are very mild and you are less likely to maintain a hot fire.

To clean the inside of the glass or wipe off fly ash, we recommend that you use a brush with soft bristles (like a paintbrush). You may clean heavy soot from the glass with very fine steel wool (0000 grade), but first, be sure the fire is out; and second, be sure that the glass has cooled to room temperature before you clean it. DO NOT ATTEMPT TO CLEAN HOT GLASS.

## Gasket Replacement

There are five areas on your stove where you should check the gasket routinely: **(1)** on the side door, **(2)** under the cast iron cooktop, **(3)** under the catalytic bypass damper, **(4)** behind the catalytic combustor, **(5)** and the ashpan door (models purchased with the ashpan). These five gaskets are the most important for maintaining high efficiency and clean burning. Close a slip of paper in these gasketed areas. There should be resistance as you pull the paper out. If there is any evidence of deterioration and/or leaking in any of these areas or if any of the gasket material in the stove becomes worn or frayed, it should be replaced. Please contact Woodstock Soapstone Company for replacement gasket and replacement instructions.

The sizes of all the gaskets on your Progress Hybrid woodstove are included in the parts list on page 31-34 of this manual.

# Routine Checks And End of Season Maintenance

Every few weeks of operation we recommend checking the chimney connector (stovepipe) and combustor (see combustor section) and cleaning, if necessary.

When the weather warms up and the burning season is over, it is a good idea to do a thorough spring cleaning and inspection of your stove and chimney system. We recommend an annual inspection and cleaning by a certified chimney sweep who has the tools and knowledge to inspect the whole system, from top to bottom. Chimney safety is an important part of responsible wood burning. The best way to gain confidence in the safety of your Progress Hybrid Woodstove is to have it serviced and inspected once a year by a professional chimney sweep. The Chimney Safety Institute of America maintains a database of certified sweeps nationwide. Go to their website [www.csia.org](http://www.csia.org) to find a professional in your area.

If you live in a climate with warm, humid summer weather, your stove may collect moisture from warm, moist, chimney downdrafts during the summer. If this happens, the moisture may wick through the gasket between the cast iron and the soapstone panels, and appear as discoloration around the edge of the exterior soapstone. If this happens, you can remove any discoloration with fine steel wool. One way to reduce the likelihood of this happening is to block the flue exit in the stove with fiberglass insulation at the end of the heating season. This will help prevent downdrafts and humidity from entering the stove. (You'll have to be careful to remember to remove the insulation before you light the stove again in the fall!)

## Creosote- Formation and Need for Removal

When wood is burned too slowly, it produces tar and other organic vapors, which combine with expelled moisture to form creosote. The creosote vapors condense in the relatively cool chimney flue of a slow burning fire. As a result, creosote residue accumulates on the flue lining. When ignited, this creosote makes an extremely hot fire.

The chimney connector and chimney should be inspected at least once every two months during the heating season to determine if creosote buildup has occurred. If creosote has accumulated it should be removed to reduce the risk of a chimney fire. Cleaning the combustor regularly will also greatly reduce creosote buildup. Under certain conditions, creosote can form rapidly.

The most likely conditions for creosote to occur are: (1) when a large number of small pieces of wood are added to a hot bed of coals and the damper is then completely closed; (2) extremely long, smoldering fires, and; (3) burning wet or green wood.

Lack of combustion air and smoldering fires usually result in dense smoke and low stack temperatures in the chimney connector and the chimney. Wet or green wood can also produce dense smoke and excessive water vapor, which can quickly lead to creosote buildup.

Creosote will accumulate faster in exterior chimneys than interior chimneys because of colder outside temperatures.

There are three stages of creosote build-up. The first is a flaky, crystal-like accumulation which can be removed with a brush. The second is a tar like coating. The third is a hard, glossy enamel like coating that is difficult to penetrate. If your chimney is heavily coated with tar or enamel like creosote, we recommend that you consult with an experienced chimney sweep about removal and prevention.

**PREVENTION:** Without question, the best way to treat creosote is to prevent its accumulation. In order to reduce the danger of accumulation, we recommend the following:

1. Burn only properly dried firewood. Dry wood burns hotter, cleaner, and expels less moisture to condense.
2. Use the catalytic combustor properly. It can reduce possible creosote accumulation by as much as 90% and improve stove efficiency at the same time. Be sure to read the section on catalytic

combustors on pages 20-23.

3. Never operate your stove for extended periods of time with the draft control completely closed. Both the wood fire and the catalytic combustor need oxygen to burn efficiently.
4. Re-establish a hot fire, and re-ignite the combustor after every reloading by opening the primary air control for about 10 minutes.
5. Check the catalytic combustor output. Use the thermometer provided with the stove to be sure that the catalytic combustor is igniting properly when you kindle a fire or reload the stove. The temperatures on the stove top should rise noticeably when the catalytic combustor is engaged.
6. Avoid long, smoldering fires. Again, the catalytic combustor is critical here. Hot firebox temperatures (with the stove top thermometer in the 400-600°F range) will produce more complete combustion and maintain proper catalytic activity.



# TROUBLESHOOTING GUIDE

<u>Problem</u>	<u>Possible Cause</u>	<u>Solutions</u>
Stove smokes	Operating technique	Open bypass and air damper prior to reloading stove
	Blocked Chimney	Examine chimney and stovepipe for blockage and creosote accumulations. Check spark arrestor screen on your cap, if you have one.
	Blocked outside airduct	Check the outside inlet for blockage caused by snow, debris, or insects.
	Oversized chimney	Reline chimney to appropriate size.
	Chimney too short	Add height (industry standard is 15ft or more).
	More than one appliance vented into flue	Disconnect other appliances, seal openings appropriately.
Back Puffing or sudden internal ignitions	Operating technique	Open bypass and air dampers before opening to reload and keep it open a few minutes after reloading.
	Burn rate too low	Open air damper to allow for hotter burn.
	Chimney down draft	In high wind areas, a specially designed wind cap may be necessary.
	Combustor plugged	Clean combustor of accumulated fly ash.
	Tight house	Dedicated air supply with outside air adaptor attachment to stove.
Combustor not glowing	Late stage of burn	Combustor does not need to be glowing to be working. Check smoke exiting chimney to help determine if combustor is working properly.
Stove burning too hot or fast	Ashpan Door is Open	Close ash door securely, check ash door gasket, check clean out door or cap secure.
	Excessive draft	Adjust air damper to lower setting.
	Extra tall chimney	Consider installing pipe damper
	High wind or hilltop location	Install wind cap on top of chimney

Insufficient Heat	Poor quality or green wood	Use only well-seasoned wood (dried at least one year). Test with kiln dried wood.
	Blocked outside air duct	Check outside air duct for blockage
	Heat going up chimney	Test with thermometer on 1st section of stovepipe– temps should drop below 300 degrees F when combustor is engaged.
Acrid odor during initial burn	Paint and/or window gasket curing	Open windows until paint or gasket is cured.
Window Dirty	First start up fire	Check gap for air guide at top of stove window inside stove. There should be a 17/64" in gap between glass and edge of cast iron plate. A smaller gap due to ash build up could restrict air flow and cause the window to soot up.
	Airflow restricted	Open-air damper in small increments until some slow flames appear. Run hot fire to burn smoke off the glass, or remove build up with glass cleaner when stove is cold.
	Smoldering fire	Green or wet wood. Burn drier wood, or open air damper slightly for a hotter burn. (see above)

## Is my Combustor still working?

Your catalytic combustor is viable for 12,000 to 14,000 burn hours. This translates, roughly, into a life span of 4 - 6 years. If the catalytic coating is not working as it should, it is not burning the gas vapors in the smoke and therefore, the smoke exiting your chimney will be darker in color. If your draft is sluggish and you have ruled out any draft related issues in the venting or in the wood supply, your combustor may not be burning the smoke vapors and too much volume is trying to pass through the honey-comb at one time. If heat output is diminished, and any other factors are ruled out, that may also be a sign that the catalytic combustor is not burning the smoke vapors, therefore not extracting maximum heat from available btu's in the wood you are burning.

# SAFETY

## Overview

To gain maximum enjoyment and benefit from your stove, you must have a safe installation. All guidelines found in this manual should be adhered to. All local and national building codes need to be followed. Having a certified installer perform all connections to an inspected chimney system is strongly advised. If you choose to perform any or all of this work yourself, it must be inspected by either a Certified Wood Stove Specialist or a Certified Chimney Specialist.

You will often find the local Fire Department to be very knowledgeable. They may inspect your house for proper warning devices, fire extinguishers and evacuation routes. Keep their phone number handy. Although many communities utilize Fire Department personnel for woodstove installation inspections, they are not usually trained as combustion venting specialists. Generally, you are best advised to use a certified specialist. The sense of security that comes with a properly installed and maintained system is worth far more than its cost.

## Installation

Your Woodstock Soapstone Stove has been thoroughly tested and listed to UL #1482 by an independent testing laboratory. UL #1482 is the standard for testing solid fuel appliances and is universally recognized by all national building regulatory agencies, (SBCC, BOCA, ICBO) and individual states. Your woodstove is a safe product, but it must be installed in accordance with the instructions in this manual. Woodstoves themselves rarely cause fires, but improper installation or careless operation are often to blame.

Follow the guidelines in the Installation chapter of this manual with regard to:

- Proper chimney and connector pipe
- Clearances to combustible surfaces and objects
- Floor protection

## Smoke and the Chimney

According to [www.woodheat.org](http://www.woodheat.org), "The chimney is the engine that drives a wood heat system". To have a safe system you must have:

- The correct type of chimney
- The correct size of chimney
- Correct location inside the house
- A properly installed system

Smoke spilling into the living space when starting a fire is an inconvenience. Smoke spilling into the house when you are away or asleep can be a major problem. In order to have all the smoke go up the chimney all the time, the chimney must have positive draft. Ideally, this draft is between 10-18 pascals, or .04-.07 inches water column, a pressure measurement, when there is no fire in the stove. A certified installer can perform a simple draft test for this.

## Heat

Your stove is HOT to the touch! Utilizing the fall away handle and use of heat resistant or insulated stove gloves can prevent serious burns when opening or closing the door, ash pan or lid of your stove.

## Ash removal

Convenient and safe ash removal is a necessity for trouble free wood burning. An ash removal container should have:

- A comfortably large capacity
- Good stability

- A top that closes securely and will not fall off
- Legs or other means of preventing downward heat flow
- A design that prevents spilling when loading

Ashes should never be dumped into a combustible container, such as a cardboard box, and an ash container should never be set on a combustible floor. Hot embers in the ashes can often stay viable for 36 hours or longer after removal from your stove.

## Precautions

- **Smoke detectors:** A smoke detector is inexpensive insurance and is required by most localities. They can either work on batteries, or can be hard-wired into your electrical system. If you have battery operated detectors, it is a good idea to replace batteries on an annual basis (i.e.: every New Year's day, or 4th of July, etc). They will sound an audible alarm in the event of the presence of smoke. Smoke will almost always precede a wood-fueled fire.

- **Fire Extinguisher:** If you burn wood, you should have at least one ABC dry chemical extinguisher. The chemical extinguisher is preferable to water because the application of cold water to hot metal stove pipes can cause metal parts to buckle or crack, thereby releasing more fuel to the fire.

- **Carbon Monoxide Detector:** These operate in a manner similar to smoke detectors but are usually user-calibrated and record minute quantities on a digital readout before sounding an audible alarm. The chances of carbon monoxide being created and escaping from your properly installed and operated stove are miniscule. You may have other vented appliances in your home that could be potential problems. The investment in a high quality carbon monoxide detector is well worth its cost in the peace of mind it affords.

- **Chimney inspection:** Your connector pipe and chimney or chimney pipe should be inspected at regular intervals. Examine the connector pipe for creosote, corrosion, loose seams, or excessive soot. Clean and replace as necessary. The chimney or chimney pipe should be cleaned and checked by a certified specialist once a year. A small mirror held at the cleanout door of a masonry chimney will be helpful. For a class A prefabricated metal pipe, some disassembly is usually required.

## Emergency Procedures In The Event of a Chimney Fire:

If you have a chimney fire or runaway fire follow these safety precautions:

1. Close the draft damper immediately, with a slow and even motion. This cuts off the supply of oxygen to the stove.
2. Call the fire department immediately.
3. Get everyone out of the house. One adult should stay in the house to check for sparks and signs of fire. Those outside should watch the roof for signs of fire.
4. If there is a danger of a fire, discharge the fire extinguisher into the stove. Do not pour or spray water directly into the chimney as rapid contraction caused by the application of cold water could cause the tile liner in the chimney to crack.
5. After the fire is out, check the stove, chimney connector and chimney carefully for signs of damage. The entire system should be thoroughly inspected by a certified chimney professional.

**Note:** Chimney fires must be put out from the bottom. The entire system must be air tight to suffocate a fire; hence the importance of having a tight cover on the chimney cleanout and not venting two appliances into a single flue.

The length of time it takes to bring a chimney fire under control depends on the amount of fuel in the stove, the rate at which it is burning and the amount of oxygen available to it. The faster it is brought under control the less severe any damage is likely to be.

# PROGRESS 209a PARTS LIST

## Cast Iron Parts

P-301	Base
P-302	Leg
P-303	Cast iron cook top
P-307	Top
P-309	Back
P-310	Front
P-311	Fettle/ Andirons
P-313-R	Right side doorframe
P-313-L	Left side doorframe
P-314	Door
P-315	Door stone retainer
P-316	Door latch
P-318-A	Bottom fill plate
P-319	Ash grate
P-320	Left air channel
P-321	Right air channel
P-322	Fireback dome (kettle)
P-323	Front air manifold/ wash
P-324	Stone retainer – non-door side
P-325	Catalyst base – bypass plate
P-326	Catalyst top
P-327S	Bypass door
P-329	Fall-Away Handle
P-330	Corner
P-331	Flue cover plate
P-332	Flue collar
P-333	Escutcheon

*All cast iron parts designed by Woodstock Soapstone Company*

## Steel/Sheet Metal Parts

K-533-	Stainless Steel Catalyst 2.5H" x 17"L x 2.5"D x 49 cpsi
W-312	Window clips
P-318B	Bottom Heat Shield, fill plate type
K-334a	Air Damper Assembly

P-353P	Stone edge liner
P-363	Fireback
P-364L	Left side fireback retainer
P-364-R	Right side fireback retainer
P-364-B	Fireback retainer, back edge
P-365	Front over glass
P-366	Front under glass
P-367	Left side – non-door style
P-368	Left side – door style
P-369	Right side – door style
P-370	Right side – non-door style
P-371	Bypass hold down
P-372	Bypass lift guide
P-374	Bypass activation shaft
P-375	Bypass handle
P-376	Rear stone retainer
P-377	Int. Corner stone retainer
P-378	Top heat shield
P-386	Damper knob
P-387	Door ring handle
K-388	Top stone medallion
P-390	Door handle spacer
P-391	Cook top handle

*All steel parts manufactured by Woodstock Soapstone Company*

## Soapstone Parts

	#pcs	
P-347	Int. front corner	2
P-348	Int. right rear corner	2
P-350	Ext. full side	1
P-351	Ext. over-the-door	1
P-352a	Ext. over-the-front	1
P-352b	Ext. under-the-front	1
P-353	Top stone	1
P-354	Corner	4
P-355	Ext. door	1

P-356a	Int. upper side (front)	1
P-357a	Int. upper side (rear)	1
P-358	Int. bricks	8
P-359	Int. back (middle)	1
P-360	Int. under-the-door	1
P-361	Top stone ctr.	1
P-361L	Top stone left	1
P-361R	Top stone right	1

*All soapstone parts cut and fabricated by Woodstock Soapstone Company*

## Other:

P-2500	UL/EPA Cert label
P-2491	Ash door caution label
P-2472	Tie rod for PH
P-2802	Pallet for PH
P-385E	Window glass
P-385E-IR	Int. glass
10"	Probe Thermometer
	Surface Thermometer

## Ash pan assembly:

P-335	Ash pan
P-336	Ash pan cover
P-337	Ash pan holder
P-338	Ash door inner
P-339	Ash door outer
P-340	Ash door handle
P-341	Ash box bottom heat shield

## Rear heat shield assembly:

K-384	Rear heat kit
-------	---------------

## Commonly Replaced Gaskets

<u>Part #</u>	<u>Desc.</u>	<u>Location</u>	<u>Density</u>
21050	.187 Round	Behind Air Damper Assembly	LD2
21085	.250 Round	Catalytic Combustor Seal	LD2 density
21085	.375 MX Round	Under Cooktop (P-303)	LD2 density
21085	.250 Round	Flue Cover Plate	LD2 density
21085	.250 Round	Flue Collar	LD2 density
21085	.250 Round	Under Bypass Door	LD2 density
21063	.500G Round	Loading Door Gasket	LD1 density
21158	.500G Round	Ash door inside	LD1 density

<b>MODEL 209a SOAPSTONE GUIDE</b>				
		<b>THICKNESS</b>	<b>HEIGHT</b>	<b>WIDTH</b>
<b>EXTERIOR SOAPSTONE</b>				
W-350	FULL SIDE	0.75	20.396	13.039
W-351	OVER DOOR	0.75	5.458	13.039
W-352a	OVER FRONT	0.75	3.296	20.539
W-352b	UNDER FRONT	0.75	3.075	20.539
W-353	TOP	1.125	12.494	22.958
W-354	CORNER (4)	0.75	20.396	3.092
<b>INTERIOR SOAPSTONE</b>				
W-355	DOOR	0.75	9.64	7.51
W-356a	UPPER SIDE FRONT	1.125	5.868	5.84
W-357a	UPPER SIDE REAR	1.125	4.304	6.984
W-358	BRICKS (8)	1.125	8.535	3.2
W-359	BACK MIDDLE	1.125	8.535	5.7
W-360	UNDER DOOR	1.125	2.22	12.85

# BOTTOM HEAT SHIELD DIAGRAM



NOTE: The fill plate must be installed inside the firebox before the bottom heat shields are attached.



Bottom fill plate  
P-318

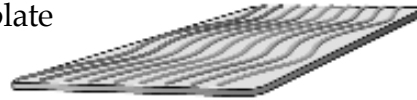

Shield #1  
P-318b

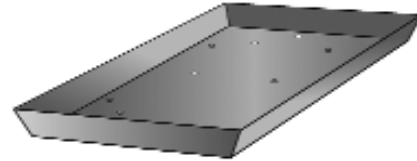

Shield #2  
P-318c

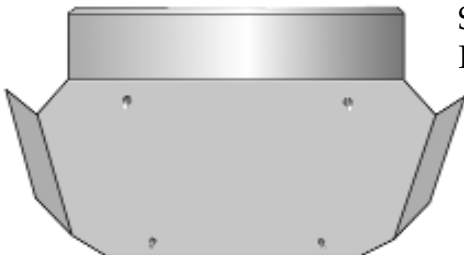
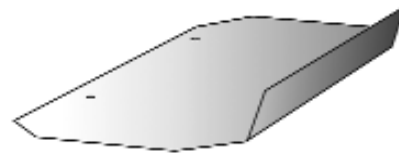

Shield #3  
P-318d

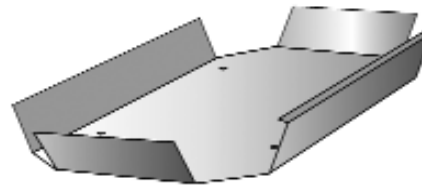

Detailed instructions and hardware are included with the bottom heat shield kit. If you have any installation questions, please call us toll free at 1-800-866-4344

# ASH PAN DIAGRAM

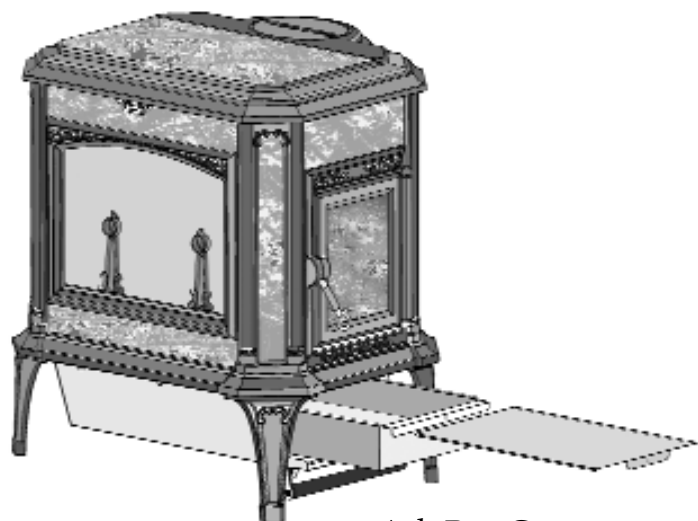
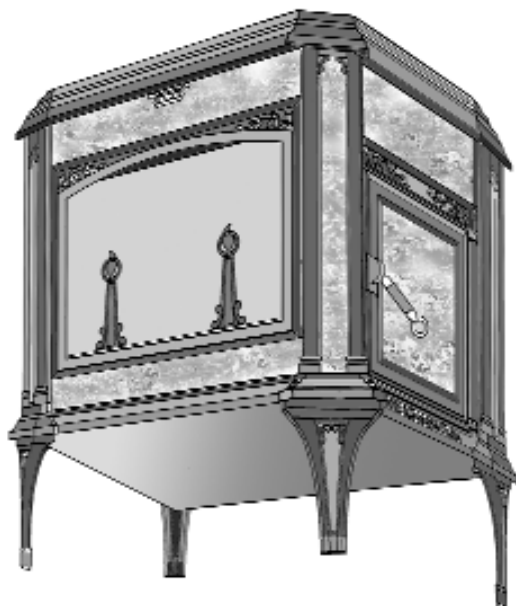

Ash Pan Cover  
P-336

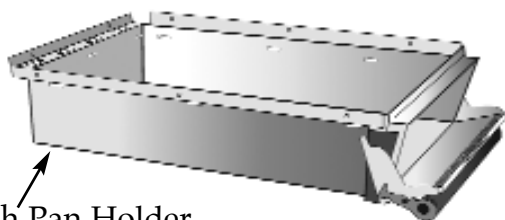

Ash Pan Holder  
P-337

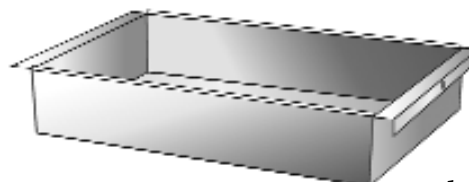
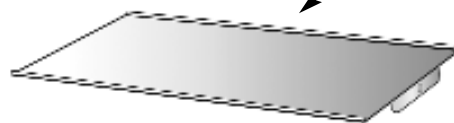

Ash Pan  
P-335

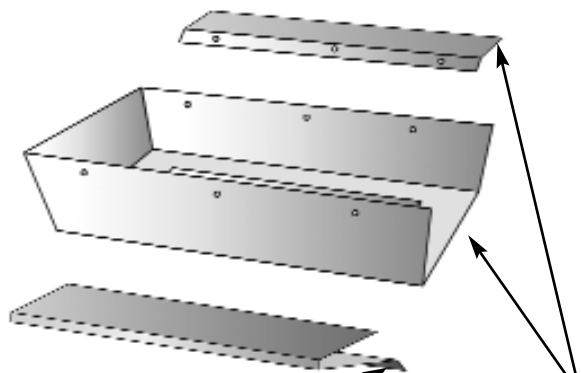

Ash box bottom  
heat shield  
P-341

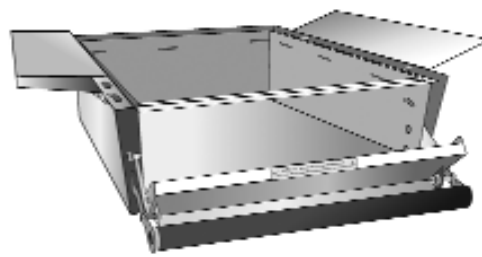

Detailed instructions and hardware are included with the ash pan kit. If you have any installation questions, please call us toll free at 1-800-866-4344



# DIMENSIONS & SPECIFICATIONS

H x W x D (10" Standard Legs)..... 33.5"x30.5"x25"  
 HxWxD (5" Short Legs)..... 28.5"x30.5"x25"  
*Ash pan unavailable with short legs*  
 EPA 2020 Certified..... Yes  
 Listed to UL 1482..... Yes  
 Flue Exit..... Top or Back  
 EPA Cordwood Emissions Rating ... 0.63 grams/hr  
 Flue Size..... 6"  
 EPA HHV Efficiency .....78.5%  
 EPA LHV Efficiency ..... 84.4%  
 Flue Height to Center (Standard Legs)..... 27.75"  
 Catalytic Combustor & Secondary Air .... Standard  
 Flue Height to Center (Short Legs)..... 22.75"  
 Bottom Heat Shield..... Standard

Weight..... 700 lbs.  
 Ash Pan..... Optional  
 Loading Door..... Right or Left  
 Back Clearance (no protection)..... 36"  
 Loading Door Size (HxW)..... 11"x9"  
 Back Clearance (w/Heat Shield Kit)..... 7"  
 Draft Control..... Manual  
 Side Clearance..... 24"  
 Wood Length (Maximum)..... 22"  
 Firebox Size..... 2.8 Cubic ft.  
 Viewing Window (HxW)..... 12.25" x 16"  
 Burn Time..... 8-16 hrs.  
 Heat Output Range..... 13,149-47,220 BTU/hr  
 Area Heated..... 1,600-2,200 sq. ft.

